

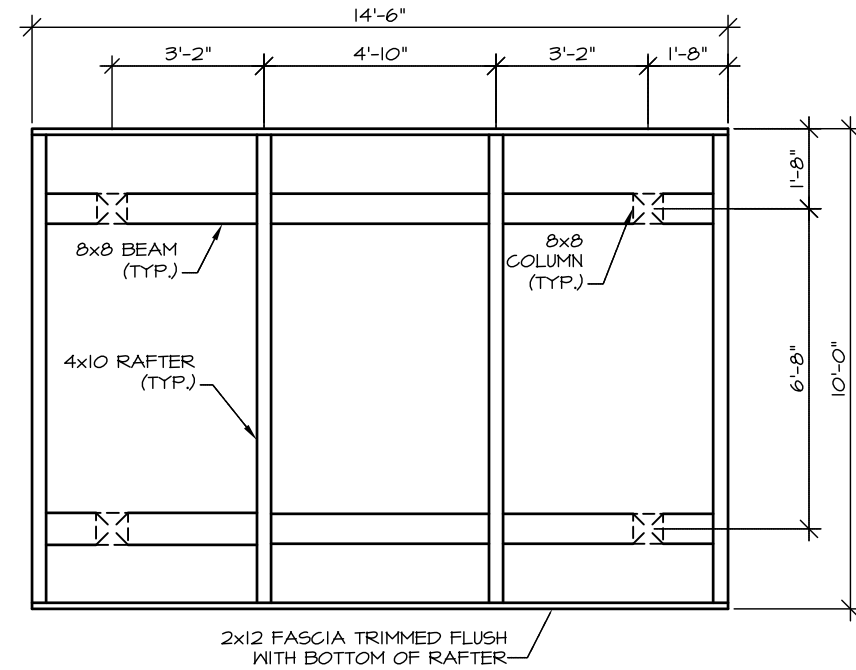

PREPARED: RBM/JAS
 DRAWN: AT/RBM/JAS
 REVIEWED: MPS
 DATE: JAN 2004

SHEET 1
 S-10D
 OF 3 SHEETS



- NOTES:
1. ALTERNATE ORIENTATION OF STEEL COLUMN BASES BETWEEN ADJACENT 8x8 POSTS.
 2. CHAMFER TOP EDGES OF (2) INTERIOR 8x8 POSTS 1" @ 45°.
 3. LIGHT BROOM FINISH THE CONCRETE SLAB.

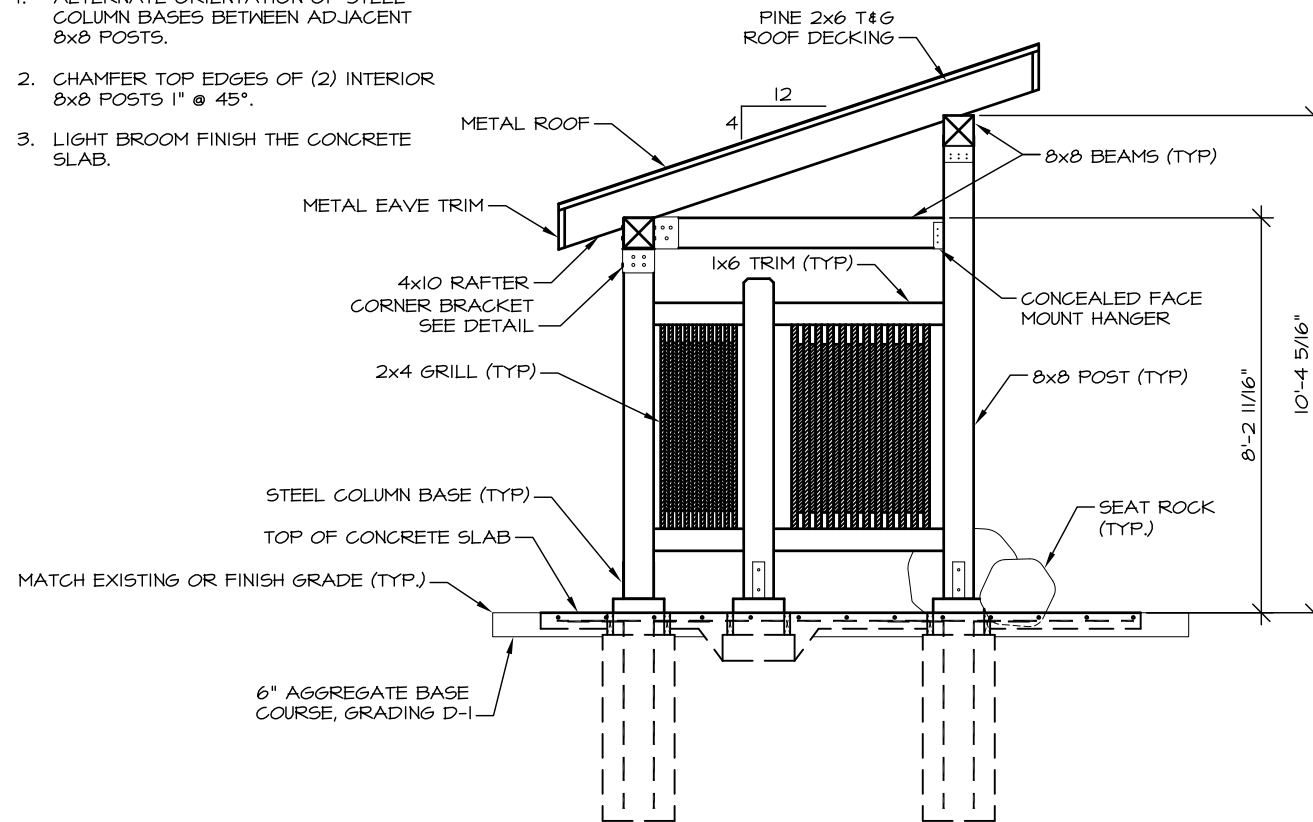

ORIENTATION KIOSK
 PLAN & PROFILE

NO.	REVISION	DATE	APPROVED
4	ADDED D-1 SHOULDER	12/10	MPS
3	CHANGED CONCRETE FOOTER, ADDED NOTE 3	12/10	MPS
2	UPDATED STATE PARK LOGO	12/10	MPS
1	CHANGED TITLE BLOCK	12/07	MPS

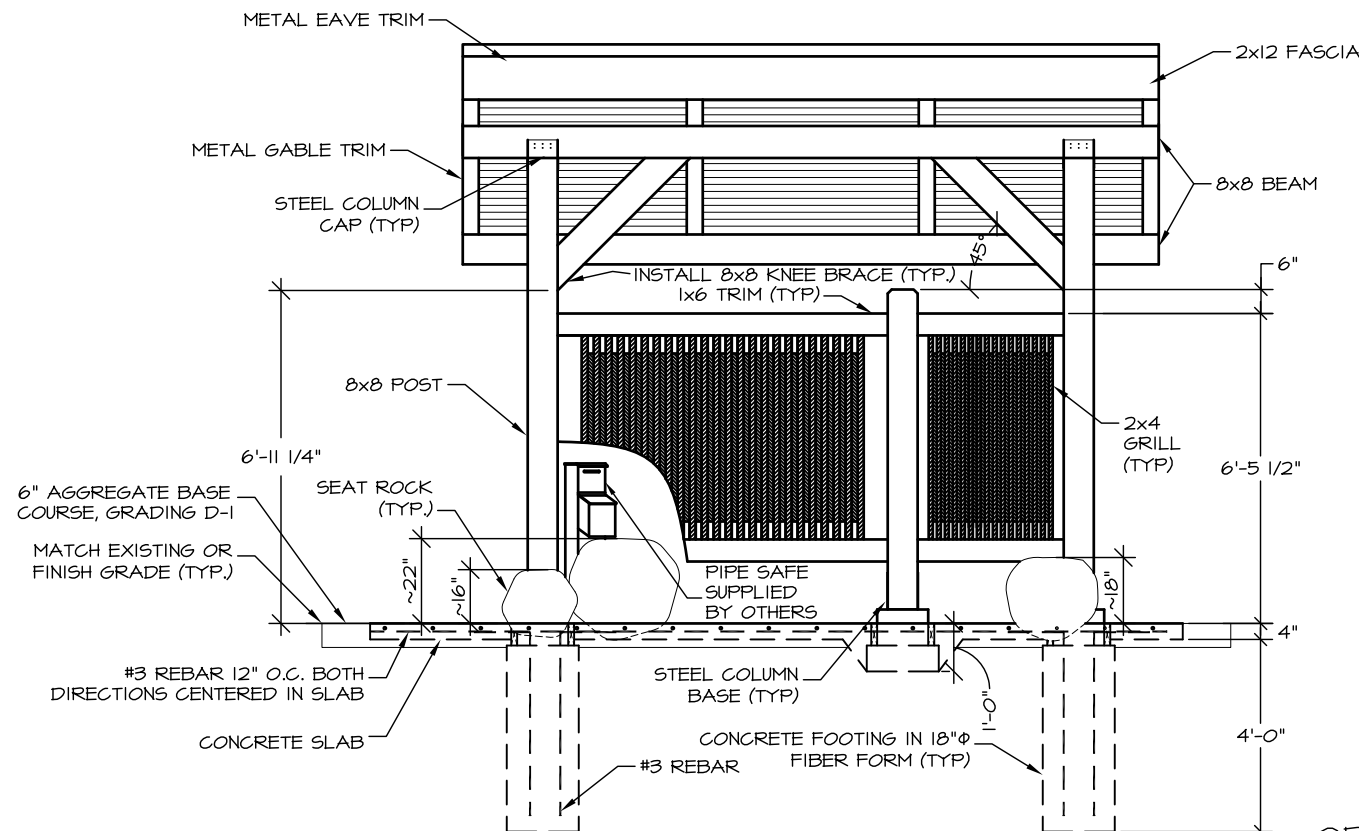
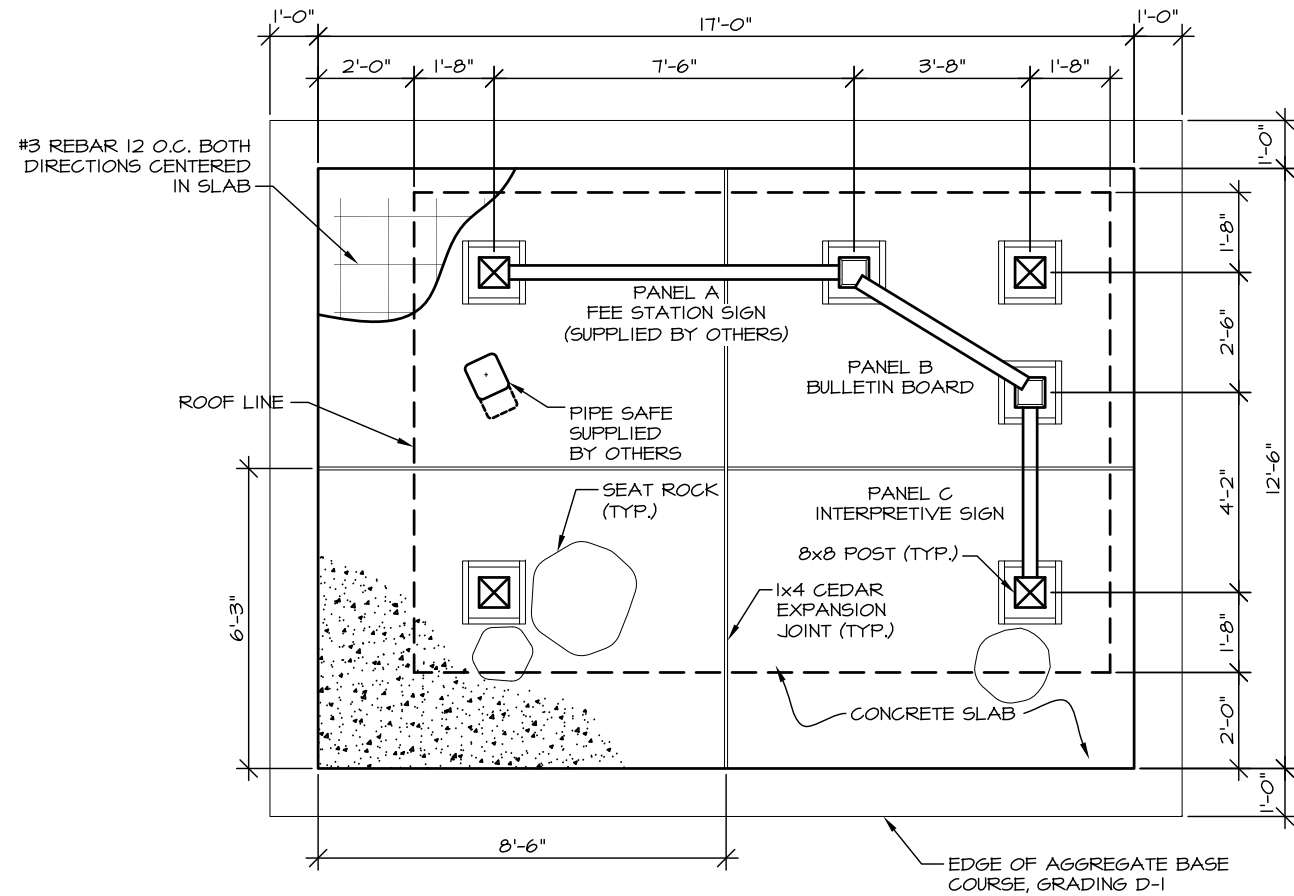

FOR INFORMATIONAL USE ONLY
 Alaska State Parks

FOR INFORMATIONAL USE ONLY
Alaska State Parks

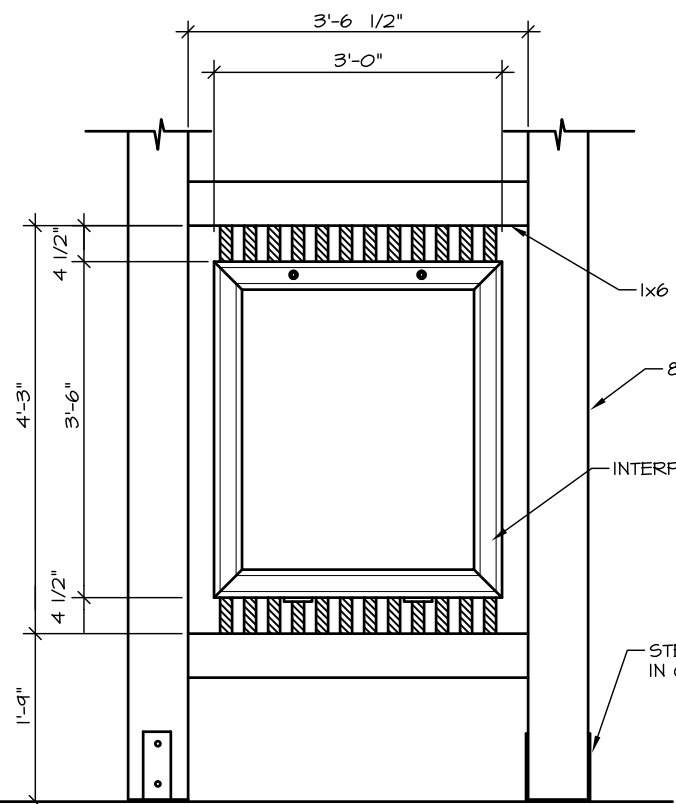

2x4 GRILL W/ INTERP PANEL
DETAILS

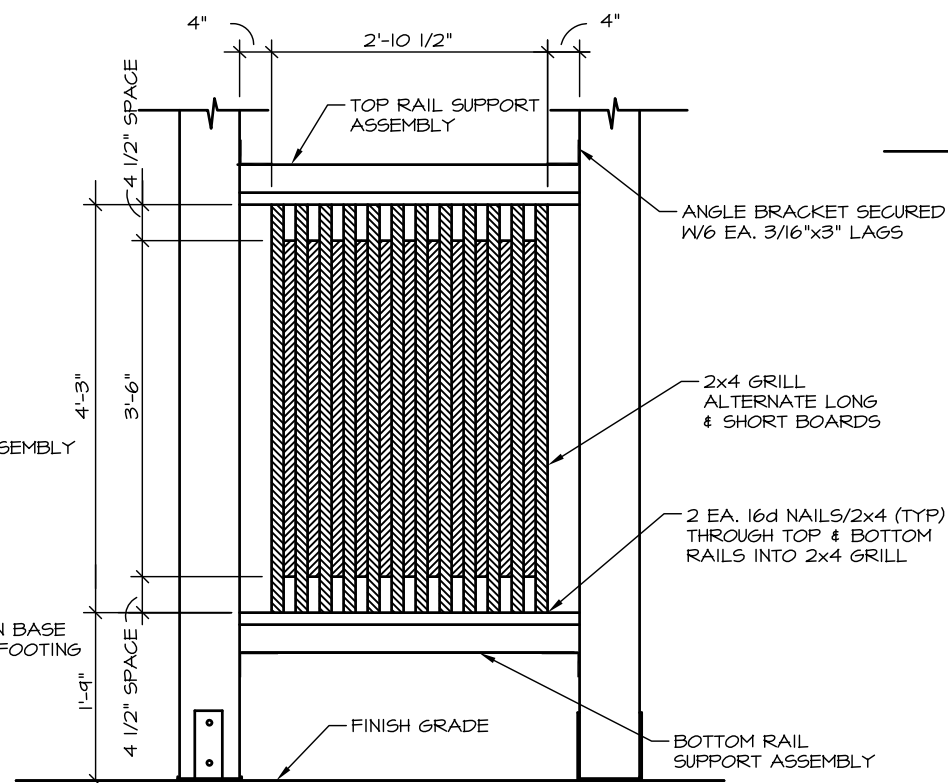

2x4 GRILL
DETAILS - INTERP PANEL &
1x6 TRIM NOT SHOWN

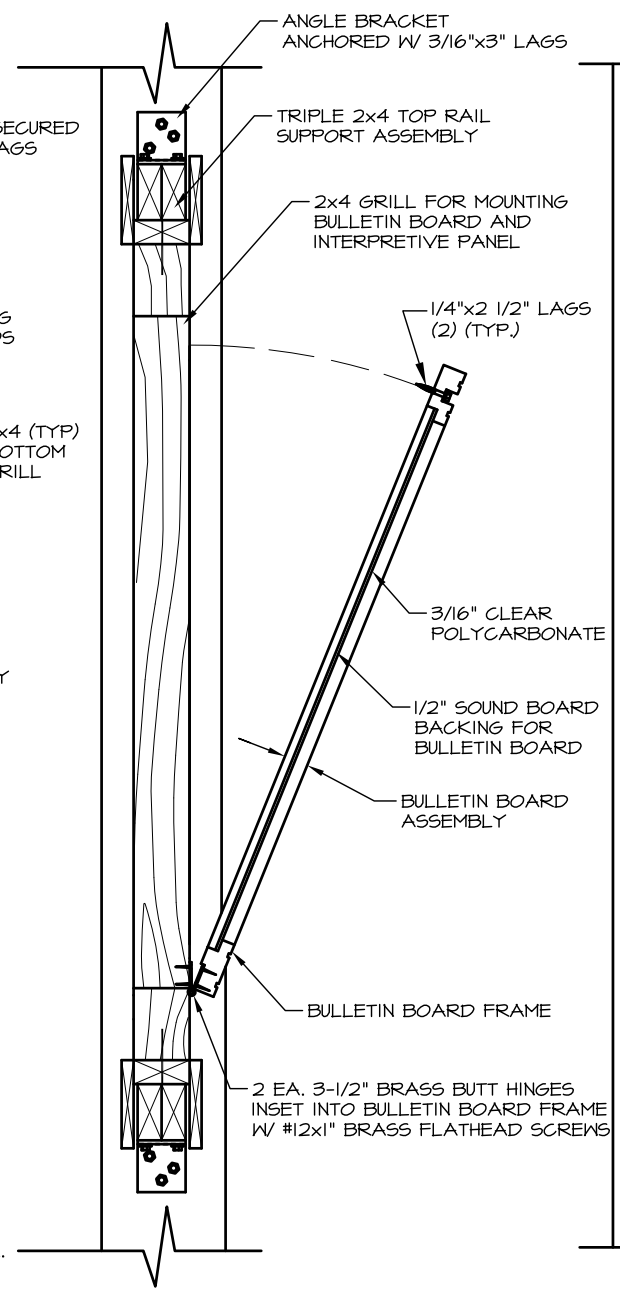

BULLETIN BOARD
SECTION

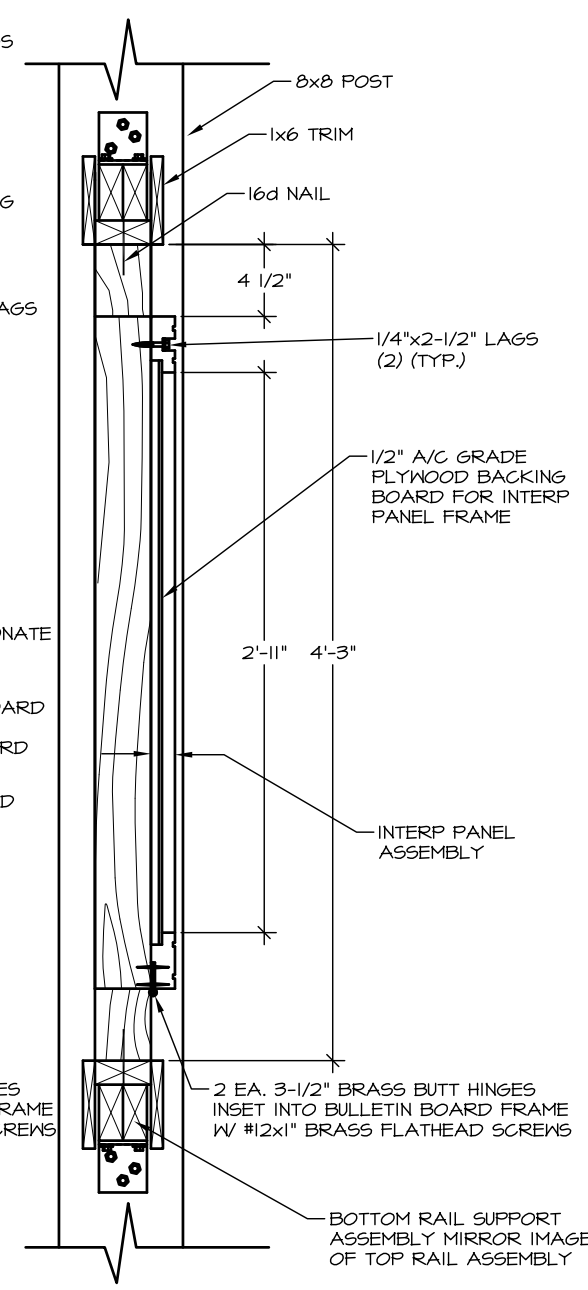

SUPPORT GRILL
SECTION

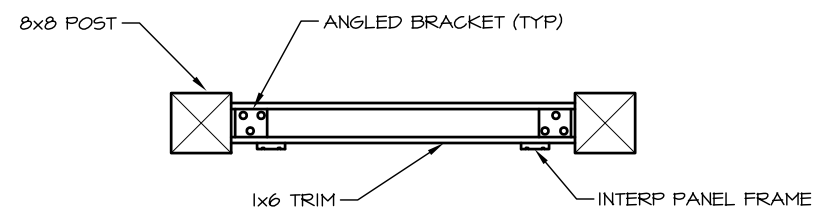

2x4 GRILL
PLAN - PERPENDICULAR TO POSTS

- NOTES:
1. NOTCH POSTS TO FIT ANGLE BRACKETS & TOP/BOTTOM SUPPORT RAILS.
2. DO NOT NOTCH POSTS FULL LENGTH OF 2x4 GRILL.

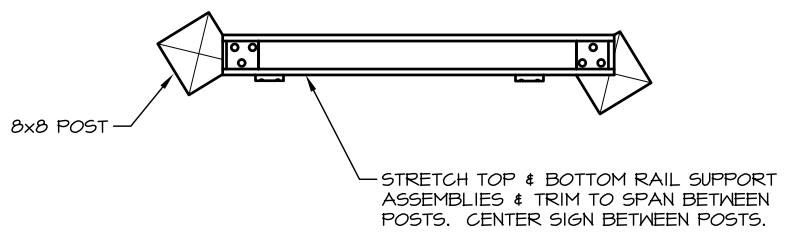

2x4 GRILL
PLAN - ANGLED TO POSTS

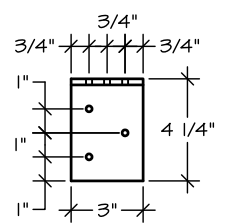

- NOTES:
1. DRILL HOLES 1/4\"/>

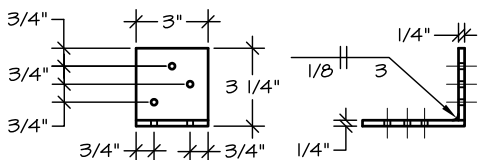

ANGLE BRACKET
DETAILS

- NOTES:
1. INTERPRETIVE PANEL ASSEMBLY CONSISTS OF INTERPRETIVE GRAPHIC BACKING BOARD AND INTERP PANEL FRAME.
2. INTERPRETIVE GRAPHIC PANEL SUPPLIED BY OTHERS MEASURES 3'-0 1/2\"/>

NO.	REVISION	DATE	APPROVED
3	CHANGED INTERP FRAME FASTENER SYSTEM	12/10	MPS
2	UPDATED STATE PARK LOGO	12/10	MPS
1	CHANGED TITLE BLOCK	12/07	MPS

STATE OF ALASKA DEPARTMENT OF NATURAL RESOURCES

ORIENTATION KIOSK

DESIGN & CONSTRUCTION SECTION



PREPARED: RBM/JAS
DRAWN: AT/RBM/JAS
REVIEWED: MPS
DATE: JAN 2004

SHEET 2
S-10D
OF 3 SHEETS

FOR INFORMATIONAL USE ONLY
Alaska State Parks

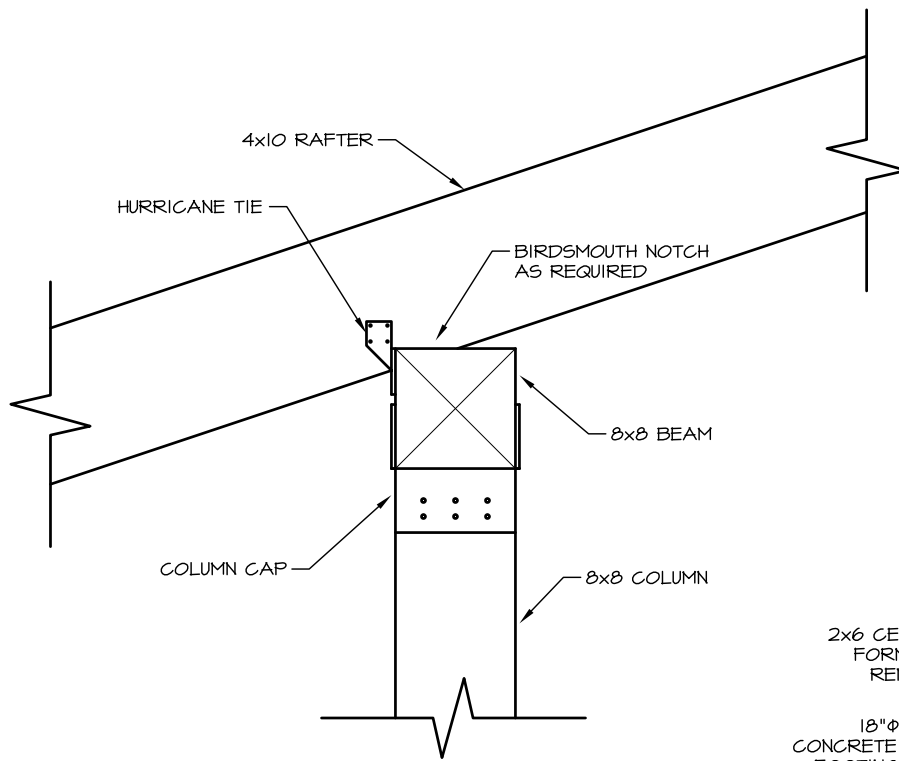

BEAM/RAFTER CONNECTION
DETAILS - 2x6 T&G DECKING & METAL ROOF NOT SHOWN

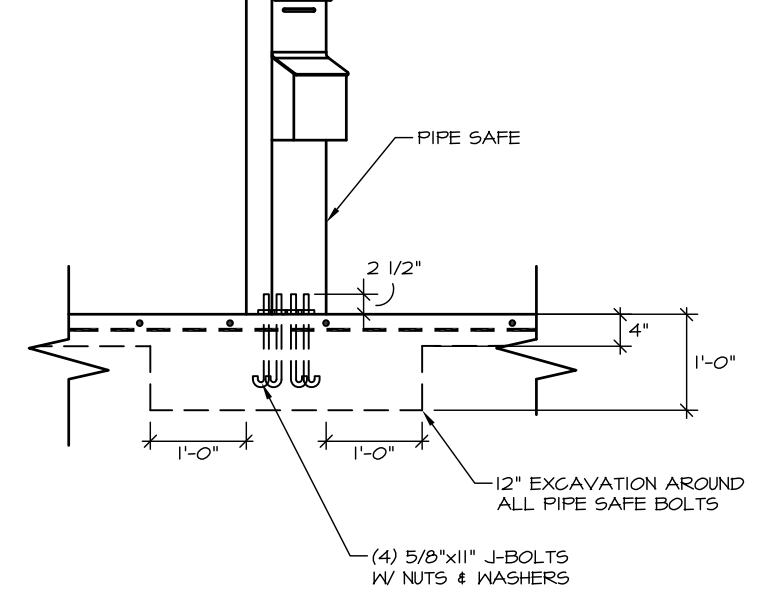
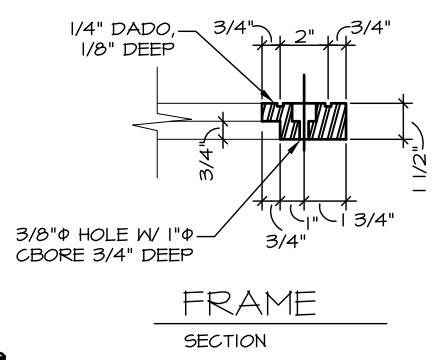

PIPE SAFE
DETAILS

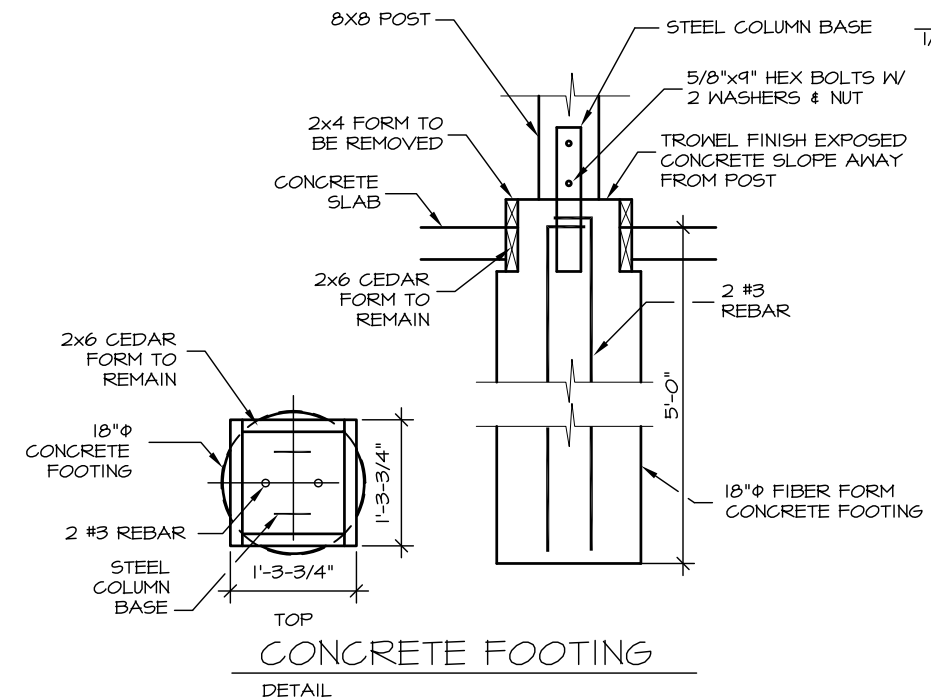

CONCRETE FOOTING
DETAIL

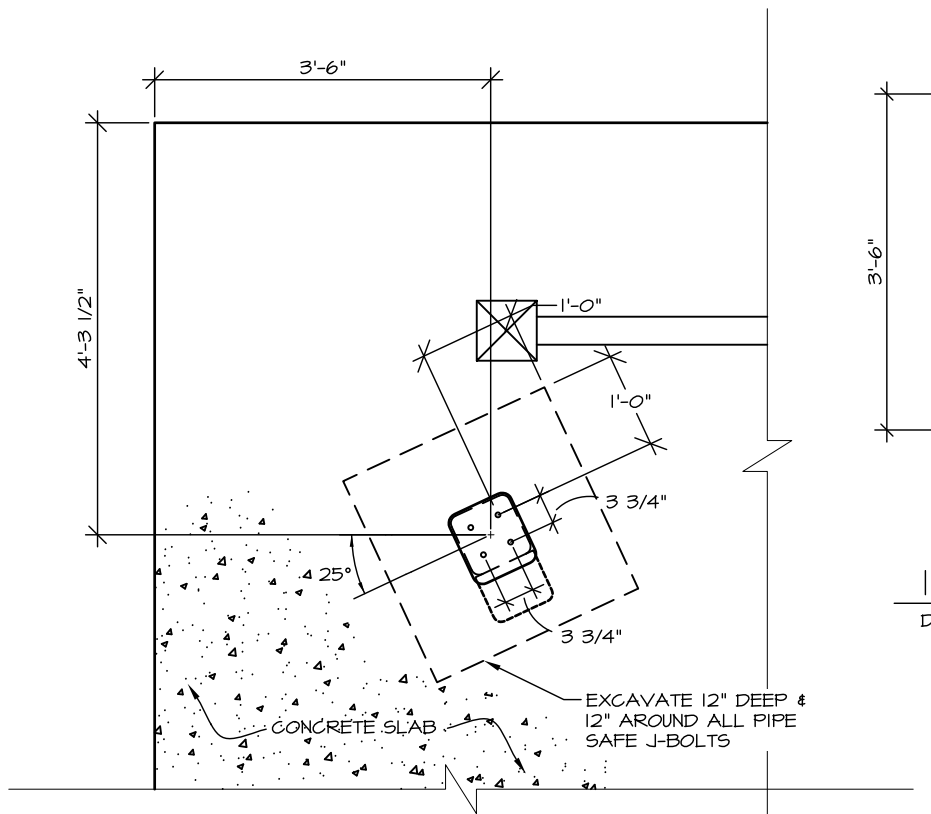

PIPE SAFE BOLT PATTERN
DETAILS

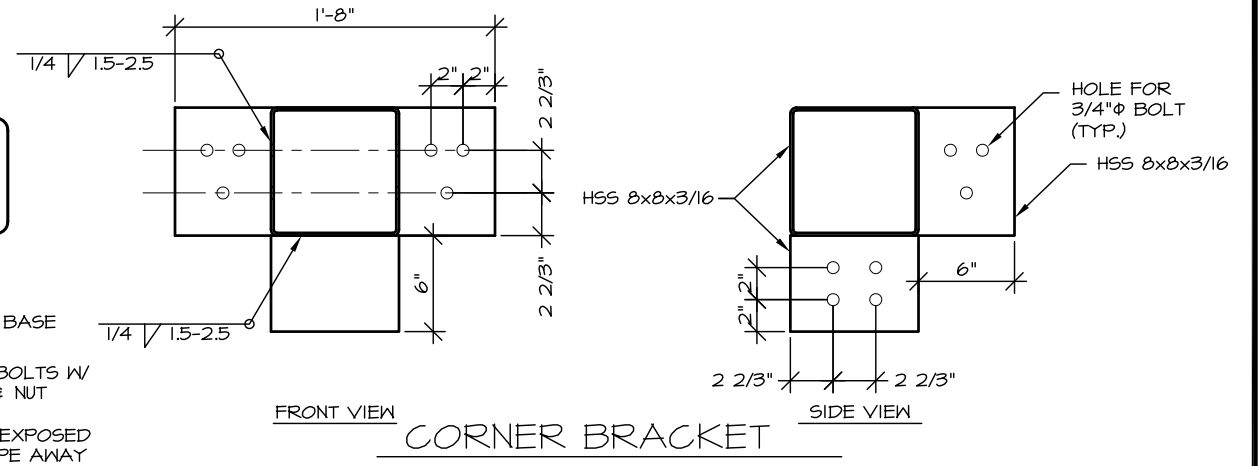

CORNER BRACKET
DETAIL

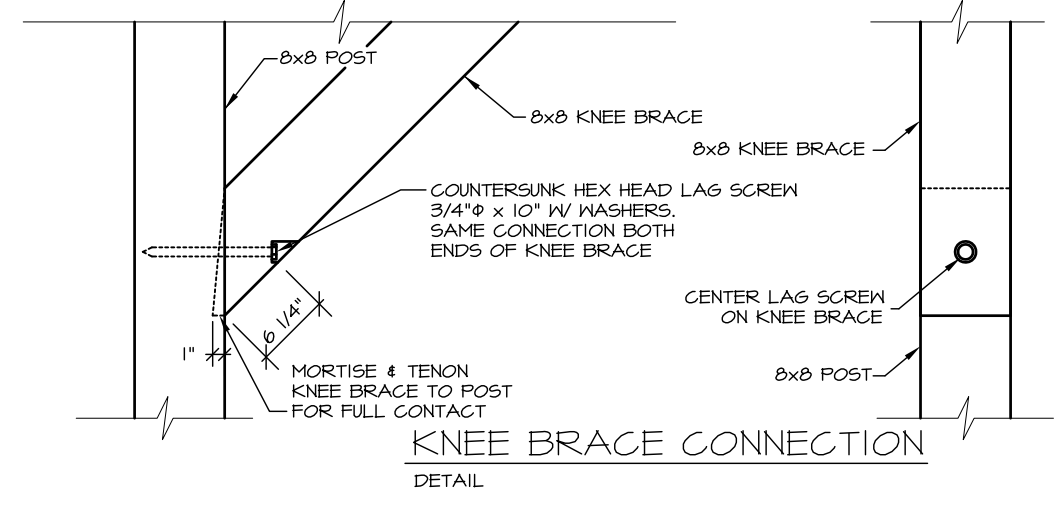

KNEE BRACE CONNECTION
DETAIL

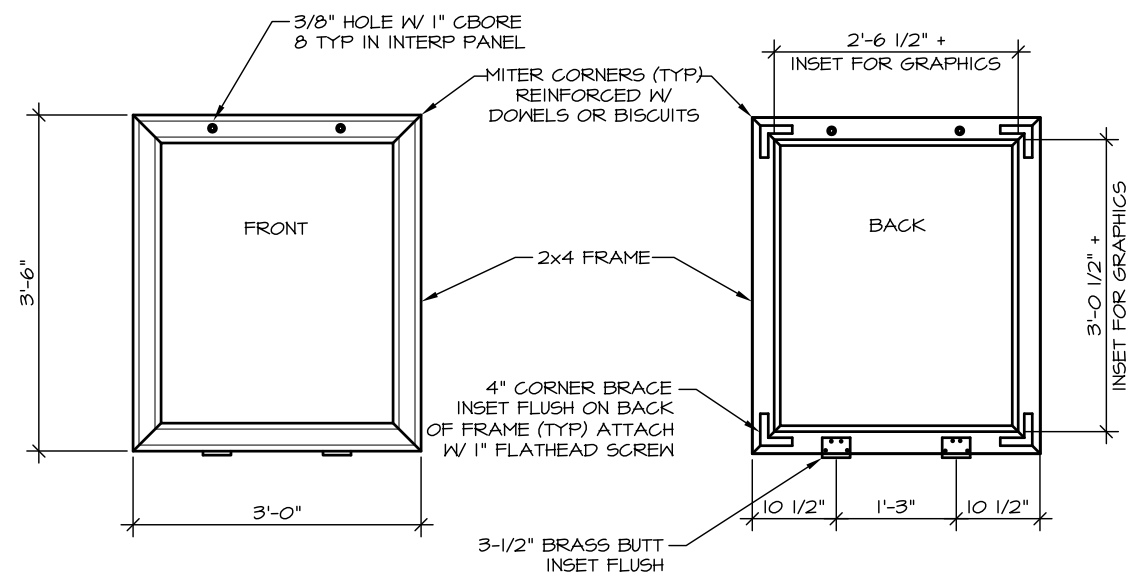

INTERP PANEL/BULLETIN BOARD FRAME
DETAILS

NO.	REVISION	DATE	APPROVED
6	INCREASED THE SIZE OF THE J-BOLTS	12/10	MPS
5	ADDED COGCRETE FOOTER DETAIL	12/10	MPS
4	ADDED KNEE BRACE CONNECTION DETAIL	12/10	MPS
3	UPDATED STATE PARK LOGO	12/10	MPS
2	CHANGED TITLE BLOCK	12/07	MPS
1	RELOCATED PIPE SAFE	8/07	MPS



PREPARED: RBM/JAS
DRAWN: AT/RBM/JAS
REVIEWED: MPS
DATE: JAN 2004

SHEET 3
S-10D
OF 3 SHEETS