

STATE OF ALASKA
 DEPARTMENT OF NATURAL RESOURCES
 DIVISION OF PARKS
 AND
 OUTDOOR RECREATION

CSP: EKLUTNA LAKE TRAILHEAD
 FACILITY IMPROVEMENTS

PROJECT NO. 73302-2

In Cooperation with the Federal Highway Administration and
 the Recreational Trail Program



Vicinity Map

SEWARD MERIDIAN, TOWNSHIP 15 NORTH, RANGE 2 EAST, SECTION 7
 LATITUDE: 61°24.6'N LONGITUDE: 149°8.9'W



INDEX

1. TITLE SHEET
2. VICINITY MAP, LEGEND, ABBREVIATIONS, AND ESTIMATE OF QUANTITIES
3. EXISTING CONDITIONS, SURVEY CONTROL, AND DEMOLITION PLAN
4. SITE PLAN
- 5-6. TYPICAL SECTIONS
7. SIGN SUMMARY
8. GRADING PLAN
9. COORDINATE POINTS

The following Division of Parks & Outdoor Rec. standard drawings apply to this project: P-6, S-10D
 The following Department of Transportation and Public Facilities standard drawings apply to this project: S-00.12, S-01.02, S-05.02, S-20.11, S-31.02

Plans developed by:
STATE OF ALASKA
 Department of Natural Resources
 Division of Parks & Outdoor Recreation
 550 W 7th Ave. Suite 1340, Anchorage, AK 99501

Recommended:

[Signature] 6/17/2024
 Date
 Rys Miranda, P.E.
 Chief, Design and Construction

Approved:

[Signature] 6/17/2024
 Date
 Ricky Gease
 Director, Alaska State Parks



ESTIMATE OF QUANTITIES			
ITEM	DESCRIPTION	UNIT	QTY
201.0009.0000	CLEARING AND GRUBBING	L.S.	ALL REQ'D
202.0001.0000	REMOVAL OF STRUCTURES AND OBSTRUCTIONS	L.S.	ALL REQ'D
203.2038.0000	DITCH LINEAR GRADING	L.F.	50
301.0001.00D1	AGGREGATE BASE COURSE, GRADING D-1	TON	987
401.0001.002B	HOT MIX ASPHALT, TYPE II; CLASS B	TON	483
611.0002.0001	RIPRAP, CLASS 1	TON	9
615.0001.0000	STANDARD SIGN	S.F.	35
618.0002.0000	SEEDING	LB	2
620.0002.000B	TOPSOIL, CLASS B	C.Y.	24
622.2020.0000	ORIENTATION KIOSK	EACH	1
622.2024.0000	CONCRETE PARKING BUMPER	EACH	21
622.2034.0000	REMOVE AND RELOCATE BARRIER ROCK	EACH	14
631.0001.0002	GEOTEXTILE, DRAINAGE, CLASS 2	S.Y.	41
640.0001.0000	MOBILIZATION AND DEMOBILIZATION	L.S.	ALL REQ'D
641.0001.0000	EROSION, SEDIMENT, AND POLLUTION CONTROL ADMINISTRATION	L.S.	ALL REQ'D
641.0002.0000	TEMPORARY EROSION, SEDIMENT, AND POLLUTION CONTROL	C.S.	ALL REQ'D
641.0006.0000	WITHHOLDING	C.S.	ALL REQ'D
642.0001.0000	CONSTRUCTION SURVEYING	L.S.	ALL REQ'D
642.0003.0000	THREE PERSON SURVEY PARTY	HOUR	5
643.0002.0000	TRAFFIC MAINTENANCE	L.S.	ALL REQ'D
647.0001.0000	HYDRAULIC EXCAVATOR, 1 CY, 100HP, MINIMUM	HOUR	5

TABLE OF ESTIMATING FACTORS	
DESCRIPTION	ESTIMATING FACTOR
AGGREGATE BASE COURSE, GRADING D-1	148 LBS/C.F.
HOT MIX ASPHALT, TYPE II; CLASS B	151 LB/C.F.
RIPRAP, CLASS 1	108 LB/C.F.

EXISTING	LEGEND	PROPOSED	
			DITCH CENTERLINE
			EDGE OF GRAVEL
			EDGE OF PAVEMENT
			EDGE OF VEGETATION
			LIMIT OF CUT SLOPE
			LIMIT OF FILL SLOPE
			MAJOR CONTOUR LINE
			MINOR CONTOUR LINE
			SURVEY CONTROL POINT/MONUMENT
			SIGN
			PARKING BUMPER

ABBREVIATIONS

Ø	DIAMETER
ε	CENTERLINE
APPRX.	APPROXIMATE
BLDG	BUILDING
C.F.	CUBIC FOOT
C.S.	CONTINGENT SUM
C.Y.	CUBIC YARD
ELEV	ELEVATION
EOG	EDGE OF GRAVEL
EOP	EDGE OF PAVEMENT
EOV	EDGE OF VEGETATION
EST.	ESTIMATE
E.G.	EXISTING GRADE
F.G.	FINISH GRADE
IN.	INCH
LB/LBS	POUND/POUNDS
L.F.	LINEAR FEET
L.S.	LUMP SUM
MIN	MINIMUM
M.E.	MATCH EXISTING
MP	MILEPOST
NO.	NUMBER
OE	OVERHEAD ELECTRICAL
OHW	ORDINARY HIGH WATER
PST	PERFORATED STEEL TUBE
PCC	PORTLAND CEMENT CONCRETE
PVC	POLYVINYL CHLORIDE
QTY.	QUANTITY
REQ'D	REQUIRED
S.A.	SQUARE FEET
STA	STATION
ST	STEEL TUBE
S.Y.	SQUARE YARD
TYP.	TYPICAL

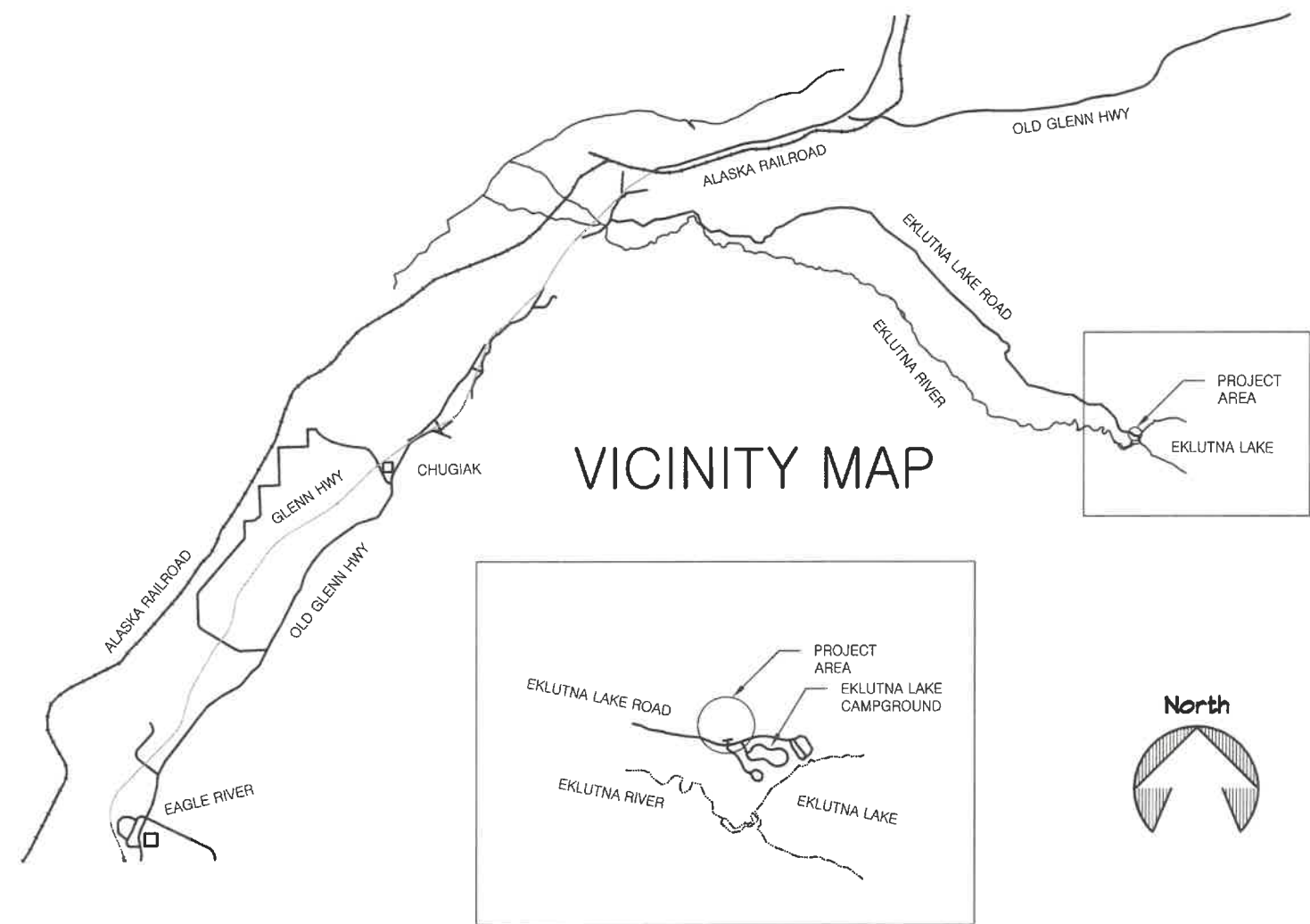

STATE OF ALASKA, DEPARTMENT OF NATURAL RESOURCES
 PLANS DEVELOPED BY: DIVISION OF PARKS AND OUTDOOR RECREATION
 550 W 7TH AVE. SUITE 1340, ANCHORAGE, AK 99501 - 907.269.8731

VICINITY MAP, ESTIMATE OF QUANTITIES,
 ESTIMATING FACTORS, LEGEND, AND
 ABBREVIATIONS

CSP: EKLUTNA LAKE TRAILHEAD
 FACILITY IMPROVEMENTS
 PROJECT No. 73302-2



PREPARED: EEH
 DRAWN: EEH
 REVIEWED: D&C
 DATE: 4/5/2024

SHEET
2
 OF 9 SHEETS

REMOVAL OF STRUCTURES AND OBSTRUCTIONS				
DESCRIPTION	LEGEND	UNIT	QUANTITY	REMARKS
WOOD PARKING BUMPER		EACH	21	REMOVE & DISPOSE
SIGN POST AND ASSEMBLY		EACH	11	REMOVE & DISPOSE
FEE STATION		EACH	1	REMOVE & DISPOSE

SURVEY CONTROL POINT SUMMARY			
CONTROL POINT #	NORTHING	EASTING	ELEVATION
1	10000.0000'	5000.0000'	100.00'
2	9749.1153'	4987.6307'	85.86'
3	9951.7818	5283.1649	91.56
4	10051.1798	5211.4525	101.1500

- NOTES:
1. SURVEY DATA BASED ON A ALASKA STATE PARKS SURVEY PERFORMED ON JUNE 28, 2021, JULY 22, 2022, AND SEPTEMBER 9, 2023.
 2. STATE PLANE COORDINATE SYSTEM ZONE 4

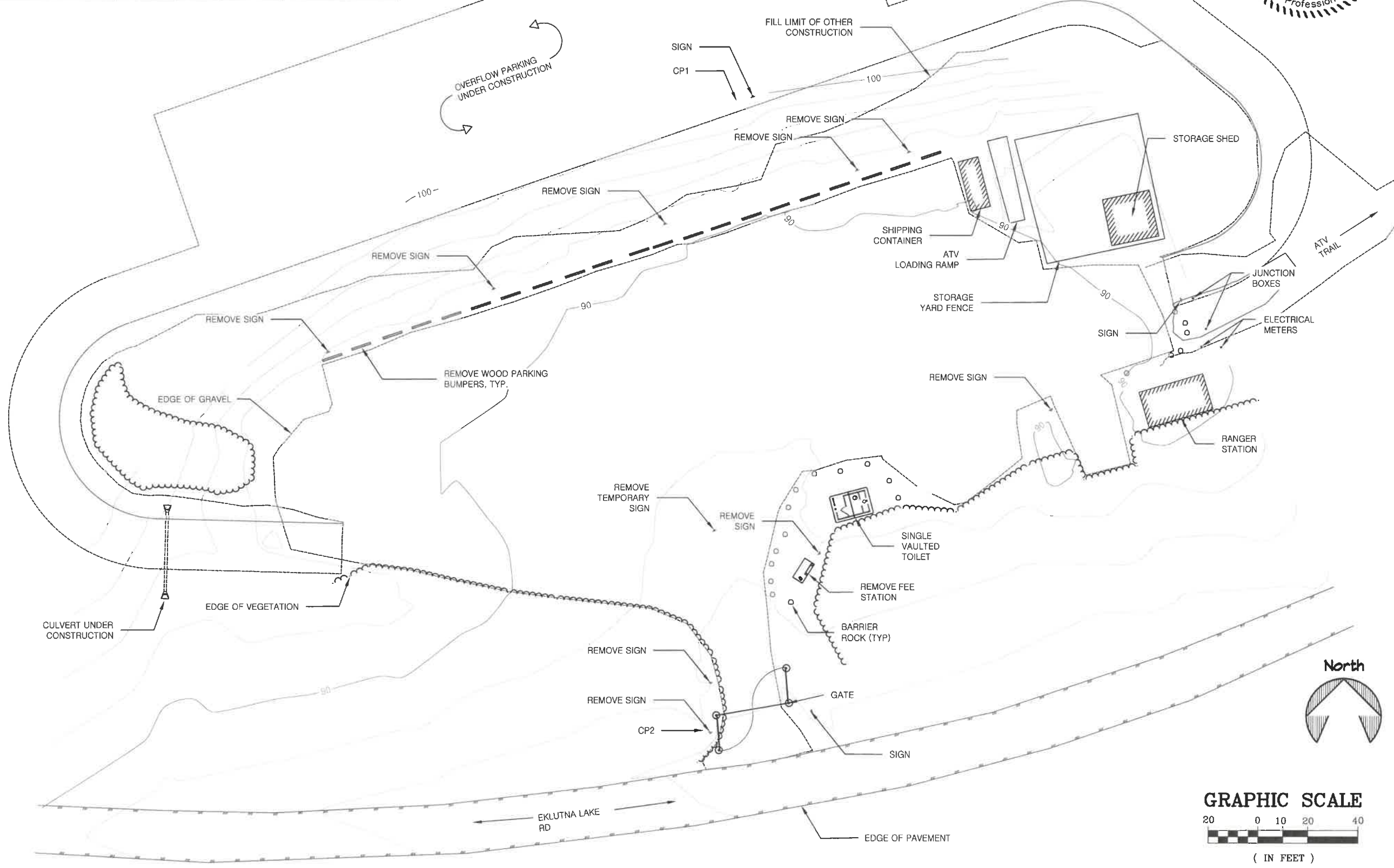

STATE OF ALASKA, DEPARTMENT OF NATURAL RESOURCES
 PLANS DEVELOPED BY: DIVISION OF PARKS AND OUTDOOR RECREATION
 550 W 7TH AVE. SUITE 1340, ANCHORAGE, AK 99501 - 907.269.8731

EKLUTNA LAKE TRAILHEAD
 FACILITY IMPROVEMENTS
 PROJECT No. 73302-2

EXISTING CONDITIONS, SURVEY
 CONTROL, AND DEMOLITION PLAN



PREPARED: EEH
 DRAWN: EEH
 REVIEWED: D&C
 DATE: 3/15/2024

SHEET
3
 OF 9 SHEETS

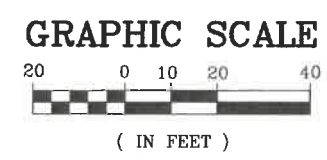

NOTES:

1. FINAL BARRIER ROCK LOCATION WILL BE FIELD LOCATED BY ENGINEER.



STATE OF ALASKA, DEPARTMENT OF NATURAL RESOURCES
 PLANS DEVELOPED BY: DIVISION OF PARKS AND OUTDOOR RECREATION
 550 W 7TH AVE. SUITE 1340, ANCHORAGE, AK 99501 - 907.269.8731

EKLUTNA LAKE TRAILHEAD
 FACILITY IMPROVEMENTS
 PROJECT No. 73302-2

SITE PLAN



PREPARED: EEH
 DRAWN: EEH
 REVIEWED: D&C
 DATE: 4/9/2024

SHEET
4
 OF 9 SHEETS

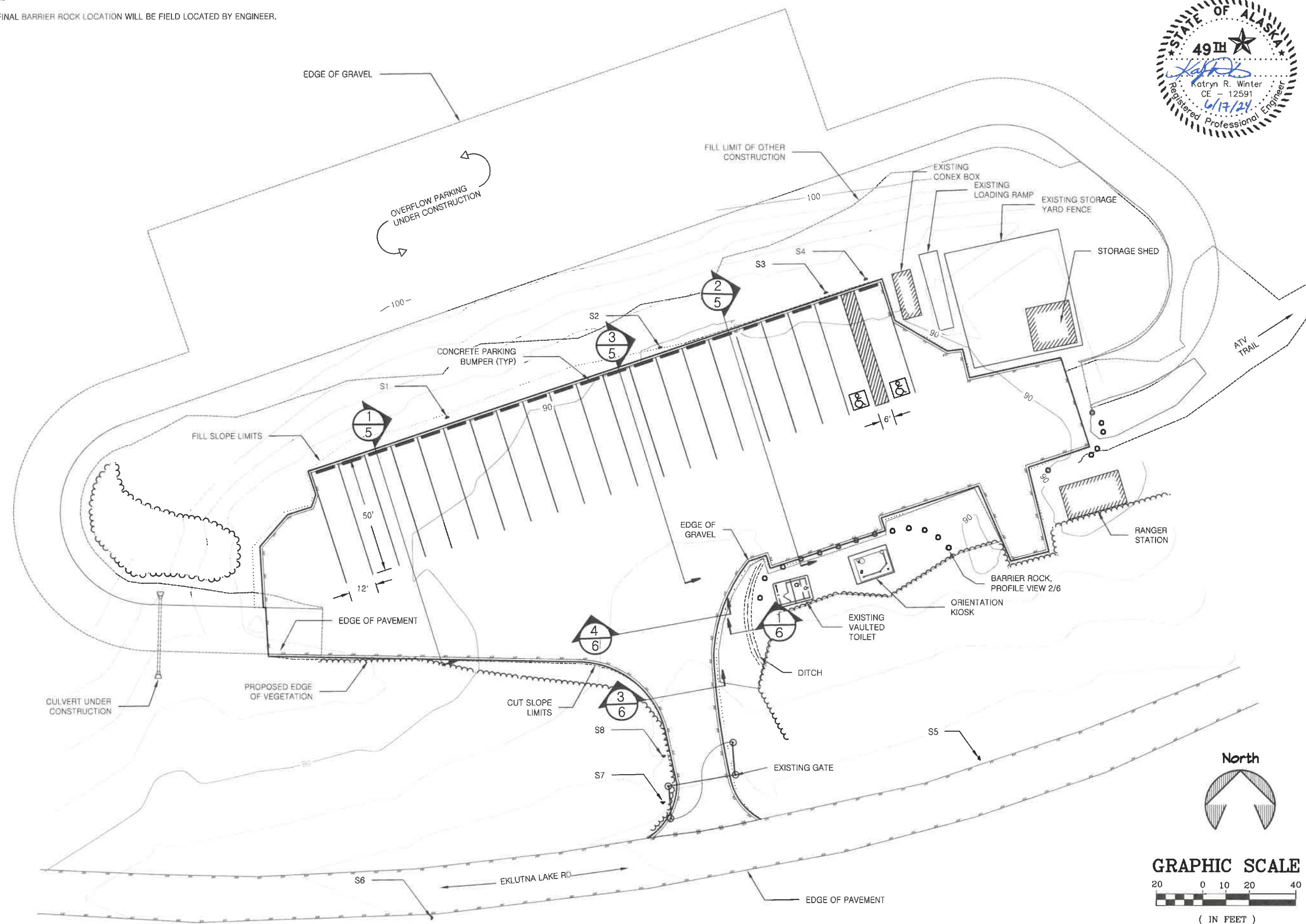

NOTES:

1. AGGREGATE BASE COURSE, GRADING D-1 USED AS FILL MATERIAL AS REQUIRED.

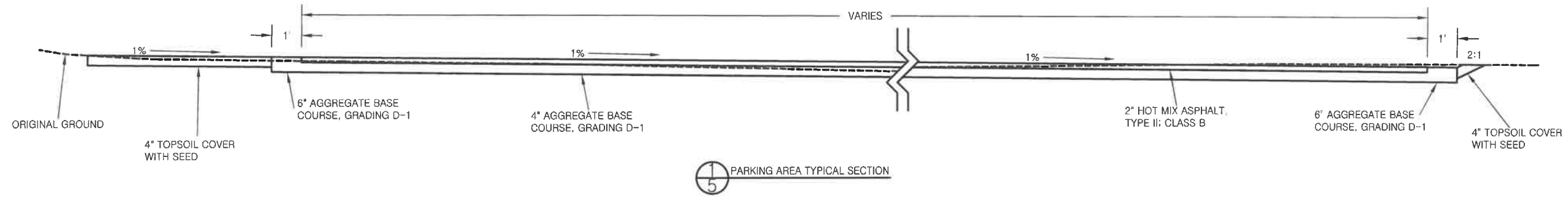

1
5 PARKING AREA TYPICAL SECTION

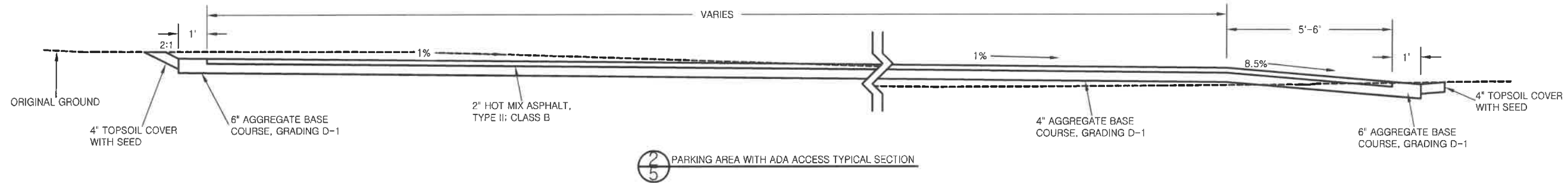

2
5 PARKING AREA WITH ADA ACCESS TYPICAL SECTION

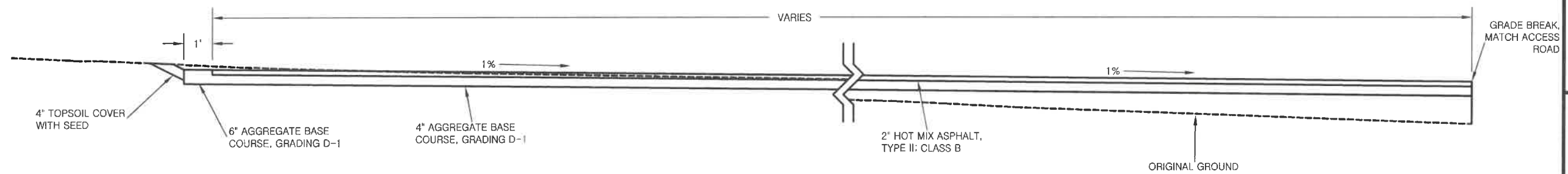

3
5 PARKING AREA WITH GRADE BREAK TYPICAL SECTION

STATE OF ALASKA, DEPARTMENT OF NATURAL RESOURCES
 PLANS DEVELOPED BY: DIVISION OF PARKS AND OUTDOOR RECREATION
 550 W 7TH AVE, SUITE 1340, ANCHORAGE, AK 99501 - 907.269.8731

EKLUTNA LAKE TRAILHEAD
 FACILITY IMPROVEMENTS
 PROJECT No. 73302-2

TYPICAL SECTIONS



PREPARED: EEH
 DRAWN: EEH
 REVIEWED: D&C
 DATE: 4/9/2024

SHEET

5

OF 9 SHEETS

NOTES:

1. AGGREGATE BASE COURSE, GRADING D-1 USED AS FILL MATERIAL AS REQUIRED.

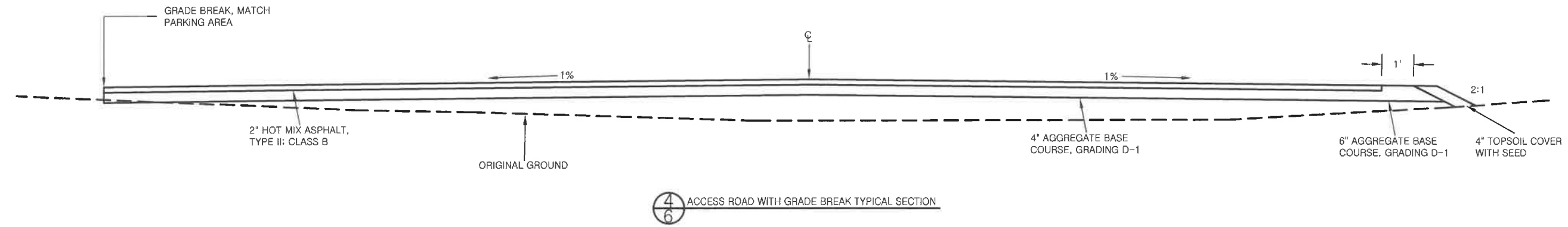
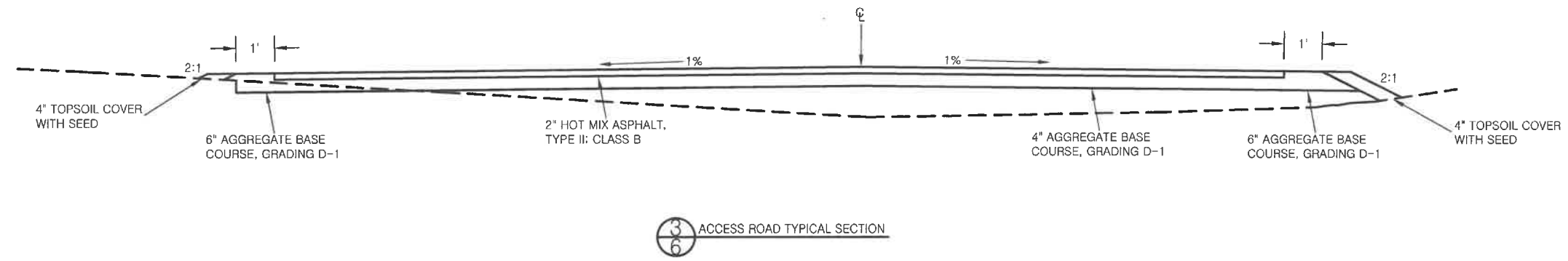
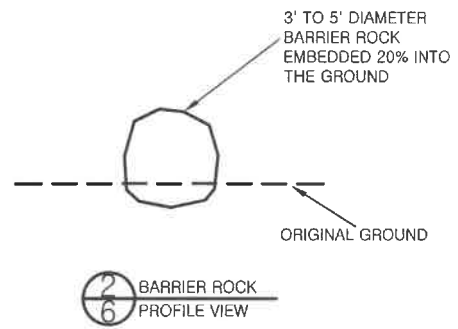
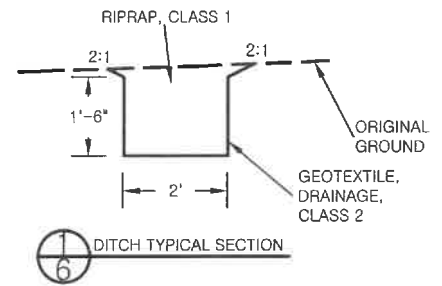

TYPICAL SECTIONS















STATE OF ALASKA, DEPARTMENT OF NATURAL RESOURCES
 PLANS DEVELOPED BY: DIVISION OF PARKS AND OUTDOOR RECREATION
 550 W 7TH AVE. SUITE 1340, ANCHORAGE, AK 99501 - 907.269.8731

EKLUTNA LAKE TRAILHEAD
 FACILITY IMPROVEMENTS
 PROJECT No. 73302-2







PREPARED: EEH
 DRAWN: EEH
 REVIEWED: D&C
 DATE: 6/17/2024

SHEET
6
 OF 9 SHEETS

ITEM 615.0001.0001 STANDARD SIGNS										
SIGN NO.	FACING	TYPE	LEGEND	SIZE (IN X IN)	AREA (S.F.)	THICKNESS (IN.)	SIGN POST DATA			
							TYPE	SIZE (IN.)	NO.	LOCATION
S1	SSE	CS-1		12X12	1	0.125	PST	2.5X2.5	1	N 9914.2876 E 4897.3892
	SSE	CS-2		12X12	1	0.125				
S2	SSE	CS-1		12X18	1	0.125	PST	2.5X2.5	1	N 9944.2479 E 4988.7312
	SSE	CS-2		18X18	1	0.125				
S3	SSE	R7-8		12X18	1.5	0.125	PST	2.5X2.5	1	N 9967.7454 E 5060.0262
S4	SSE	R7-8		12X18	1.5	0.125	PST	2.5X2.5	1	N 9973.5902 E 5077.1770
S5	ENE	RS-034		18X18	2.25	0.125	ST	2.5X2.5	1	N 9767.3848 E 5126.6945
	ENE	RS-070		18X18	2.25	0.125				
	ENE	RL-110		18X18	2.25	0.125				
	ENE	RL-170		18X18	2.25	0.125				
	ENE	CS-3		18X9	1.125	0.125				
S6	W	RS-034		18X18	2.25	0.125	ST	2.5X2.5	1	N 9698.4479 E 4891.3152
	W	RS-070		18X18	2.25	0.125				
	W	RL-110		18X18	2.25	0.125				



	W	RL-170		18X18	2.25	0.125				
	W	CS-3		18X9	1.125	0.125				
S7	N	R1-1		30X30	6.25	0.125	PST	2.5X2.5	1	N 9748.2074 E 4990.5491
S8	N	CS-4		12X18	1.5	0.125	PST	2.5X2.5	1	N 9768.0924 E 4990.7840
PROJECT TOTALS				S.F.: 35			POSTS: 8			

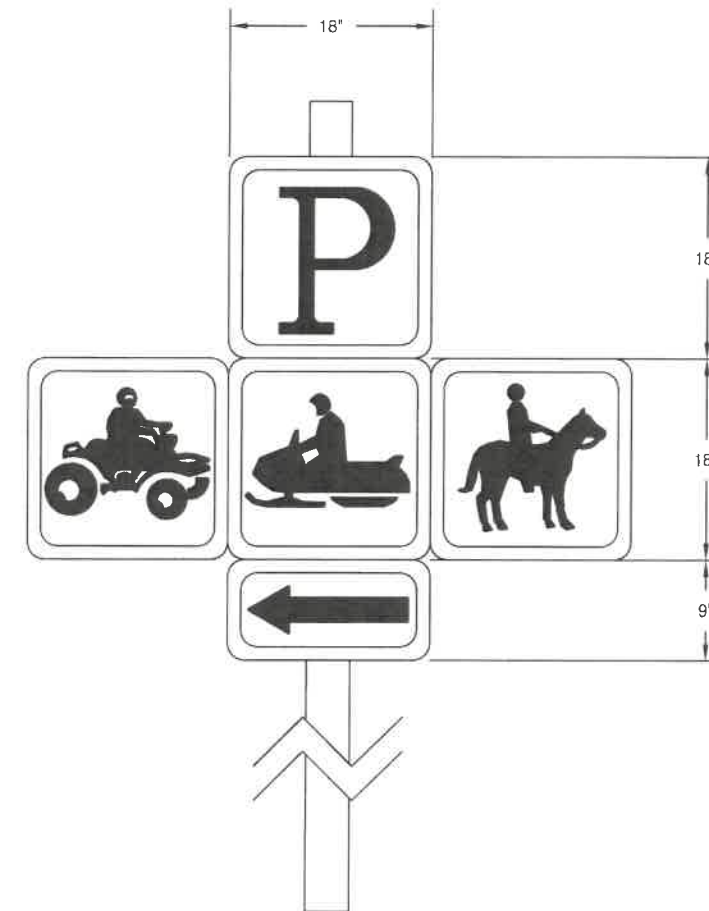

SIGNS 5 AND 6

NOTES:

- SIGNS 5 AND 6 SHALL BE LOCATED A MINIMUM OF 100' AWAY FROM THE ACCESS ROAD.

STATE OF ALASKA, DEPARTMENT OF NATURAL RESOURCES
 PLANS DEVELOPED BY: DIVISION OF PARKS AND OUTDOOR RECREATION
 550 W 7TH AVE. SUITE 1340, ANCHORAGE, AK 99501 - 907.269.8731

EKLUTNA LAKE TRAILHEAD
 FACILITY IMPROVEMENTS
 PROJECT No. 73302-2

SIGN SUMMARY



PREPARED: EEH
 DRAWN: EEH
 REVIEWED: D&C
 DATE: 4/8/2024

SHEET

7

OF 9 SHEETS

NOTES:

1. FEATURES OMITTED FOR CLARITY.

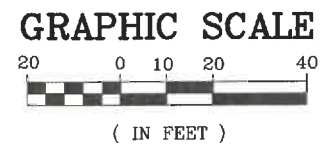
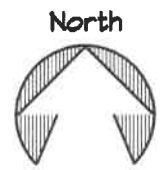
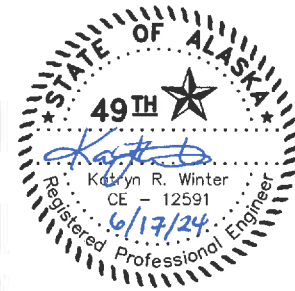

STATE OF ALASKA, DEPARTMENT OF NATURAL RESOURCES
 PLANS DEVELOPED BY: DIVISION OF PARKS AND OUTDOOR RECREATION
 550 W 7TH AVE. SUITE 1340, ANCHORAGE, AK 99501 - 907.269.8731

**EKLUTNA LAKE TRAILHEAD
 FACILITY IMPROVEMENTS
 PROJECT No. 73302-2**

GRADING



PREPARED: EEH
 DRAWN: EEH
 REVIEWED: D&C
 DATE: 4/9/2024

SHEET
8
 OF 9 SHEETS



COORDINATE POINT TABLE				
POINT #	NORTHING	EASTING	ELEVATION	DESCRIPTION
624	9733.09	4986.38	83.38	EDGE OF PAVEMENT
625	9743.26	4994.61	83.91	EDGE OF PAVEMENT
626	9756.06	4997.54	84.59	EDGE OF PAVEMENT
627	9778.43	4992.63	85.76	EDGE OF PAVEMENT
628	9800.66	4979.05	86.92	EDGE OF PAVEMENT
629	9809.82	4954.66	88.03	EDGE OF PAVEMENT
630	9811.10	4887.70	90.60	EDGE OF PAVEMENT
631	9812.38	4820.74	93.28	EDGE OF PAVEMENT
632	9858.29	4818.09	93.10	EDGE OF PAVEMENT
633	9871.52	4829.42	92.05	EDGE OF PAVEMENT
634	9874.89	4839.88	91.61	EDGE OF PAVEMENT
635	9880.99	4841.87	91.60	EDGE OF PAVEMENT
636	9890.43	4838.85	91.70	EDGE OF PAVEMENT
637	9910.90	4900.03	90.77	EDGE OF PAVEMENT
638	9931.36	4961.20	90.24	EDGE OF PAVEMENT
639	9951.82	5022.37	89.71	EDGE OF PAVEMENT
640	9972.29	5083.55	90.40	EDGE OF PAVEMENT
641	9954.94	5089.10	90.22	EDGE OF PAVEMENT
642	9941.53	5112.31	90.25	EDGE OF PAVEMENT
643	9942.27	5118.29	90.32	EDGE OF PAVEMENT
644	9929.94	5121.29	90.18	EDGE OF PAVEMENT
645	9938.76	5161.46	90.82	EDGE OF PAVEMENT
646	9902.40	5173.44	90.46	EDGE OF PAVEMENT
647	9893.44	5146.24	89.94	EDGE OF PAVEMENT
648	9857.12	5155.24	89.53	EDGE OF PAVEMENT

COORDINATE POINT TABLE				
POINT #	NORTHING	EASTING	ELEVATION	DESCRIPTION
649	9853.42	5140.79	89.34	EDGE OF PAVEMENT
650	9885.78	5126.56	89.64	EDGE OF PAVEMENT
651	9871.51	5083.03	89.08	EDGE OF PAVEMENT, GRADE BREAK
652	9865.95	5084.77	88.68	EDGE OF PAVEMENT
653	9858.16	5061.01	88.53	EDGE OF PAVEMENT
654	9850.37	5037.25	88.38	EDGE OF PAVEMENT
655	9855.92	5035.52	88.78	EDGE OF PAVEMENT, GRADE BREAK
656	9853.08	5026.85	88.79	EDGE OF PAVEMENT
657	9833.91	5015.76	88.24	EDGE OF PAVEMENT
658	9812.23	5011.29	87.28	EDGE OF PAVEMENT
659	9784.65	5013.77	85.88	EDGE OF PAVEMENT
660	9757.43	5018.87	84.47	EDGE OF PAVEMENT
661	9747.73	5023.40	83.88	EDGE OF PAVEMENT
662	9740.64	5031.25	83.41	EDGE OF PAVEMENT
663	9737.43	5012.13	83.44	CROWN
664	9763.72	5007.28	84.89	CROWN
665	9790.74	5002.29	86.42	CROWN
666	9817.75	4997.30	87.65	CROWN
667	9844.77	4992.32	89.00	CROWN, GRADE BREAK
668	9807.07	4968.19	87.52	GRADE BREAK
669	9839.75	4981.04	88.85	GRADE BREAK
670	9841.93	4992.84	88.97	CROWN, GRADE BREAK
671	9850.82	5025.08	88.66	EDGE OF PAVEMENT, GRADE BREAK
672	9863.72	5059.28	88.93	GRADE BREAK
675	9851.09	5032.71	86.67	DITCH CENTERLINE

COORDINATE POINT TABLE				
POINT #	NORTHING	EASTING	ELEVATION	DESCRIPTION
676	9828.37	5027.02	86.11	DITCH CENTERLINE
677	9806.11	5034.33	85.55	DITCH CENTERLINE

RADIUS POINT TABLE				
POINT #	NORTHING	EASTING	RADIUS	DESCRIPTION
625	9743.26	4994.61	29'	EDGE OF PAVEMENT
628	9800.66	4979.05	40'	EDGE OF PAVEMENT
657	9833.91	5015.76	69'	EDGE OF PAVEMENT
659	9784.65	5013.77	290'	EDGE OF PAVEMENT
661	9747.73	5023.40	27'	EDGE OF PAVEMENT
676	9828.37	5027.02	42'	DITCH CENTERLINE

STATE OF ALASKA, DEPARTMENT OF NATURAL RESOURCES
 PLANS DEVELOPED BY: DIVISION OF PARKS AND OUTDOOR RECREATION
 550 W 7TH AVE. SUITE 1340, ANCHORAGE, AK 99501 - 907.269.8731

EKLUTNA LAKE TRAILHEAD
 FACILITY IMPROVEMENTS
 PROJECT No. 73302-2

COORDINATE POINTS



PREPARED: EEH
 DRAWN: EEH
 REVIEWED: D&C
 DATE: 4/9/2024

SHEET

9

OF 9 SHEETS

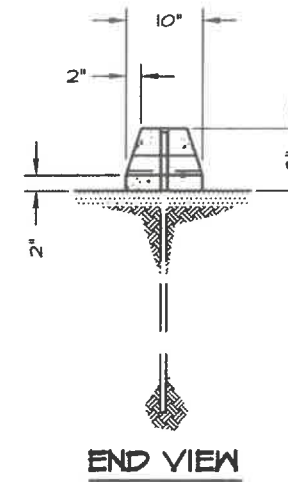
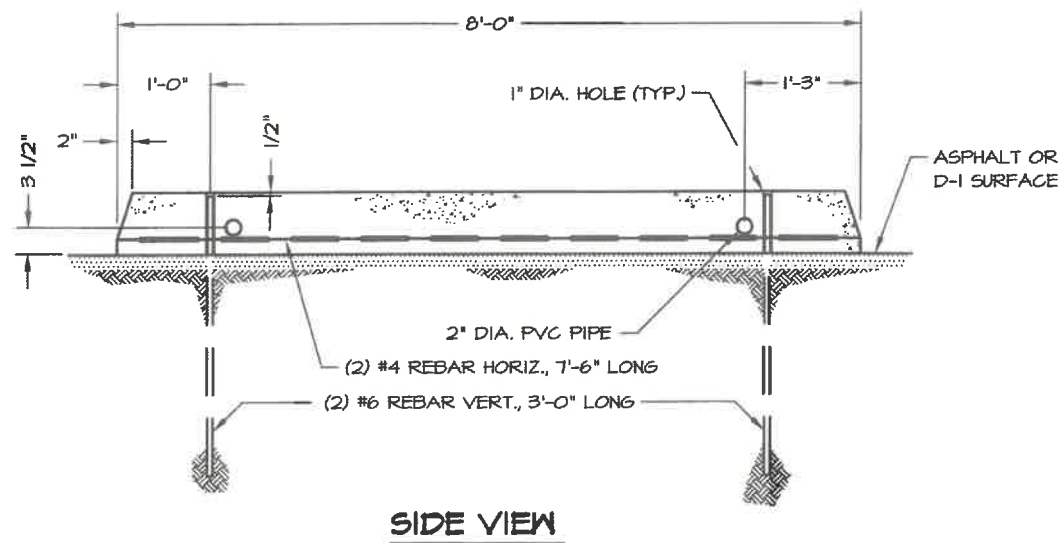

① CONCRETE PARKING BUMPER



STATE OF ALASKA DEPARTMENT OF NATURAL RESOURCES

PARKING BUMPER

DESIGN & CONSTRUCTION SECTION



PREPARED: tlc
 DRAWN: tlc
 REVIEWED: DH
 DATE: 1 MAY 94

NO.	REVISION	DATE	APPROVED
11	REPLACED STAMP	12/13	REM
10	CHANGED STATE PARK LOGO	04/10	MPS
9	CHANGED TITLE BLOCK	12/07	MPS
8	DELETED HOOD PARKING BUMPER & NOTES	10/08	MPS
7	UPDATED PRESSURE TREATMENT NOTE	12/04	MPS
6	UPDATED PRESSURE TREATMENT NOTE	3/04	MPS
5	REPLACED STAMP	3/04	MPS
4	REPLACED STAMP	3/02	DH

SHEET 1
 P-6
 OF 1 SHEETS



PREPARED: RBM/JAS
 DRAWN: AT/RBM/JAS
 REVIEWED: MPS
 DATE: JAN 2004

SHEET 1
 S-10D
 OF 3 SHEETS

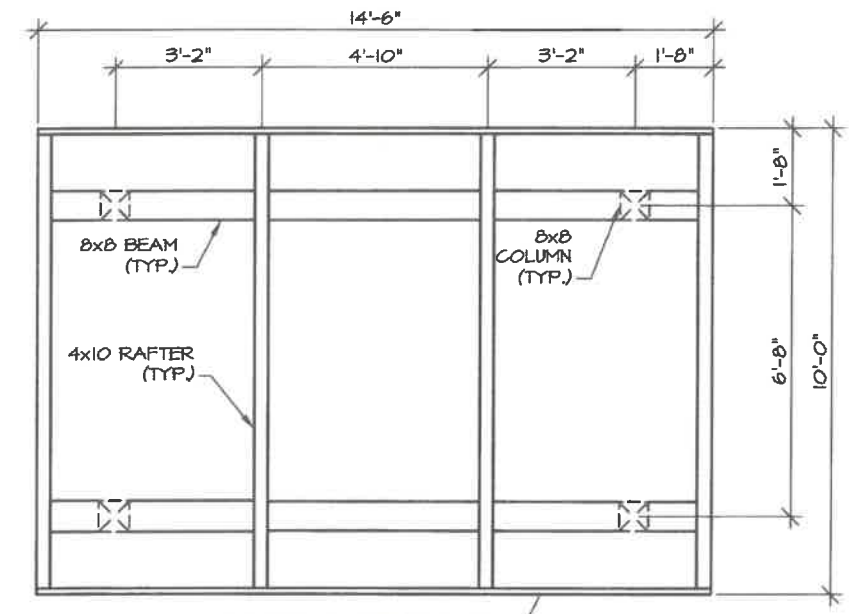

2x12 FASCIA TRIMMED FLUSH WITH BOTTOM OF RAFTER

- NOTES:
1. ALTERNATE ORIENTATION OF STEEL COLUMN BASES BETWEEN ADJACENT 8x8 POSTS.
 2. CHAMFER TOP EDGES OF (2) INTERIOR 8x8 POSTS 1" @ 45°.
 3. LIGHT BROOM FINISH THE CONCRETE SLAB.

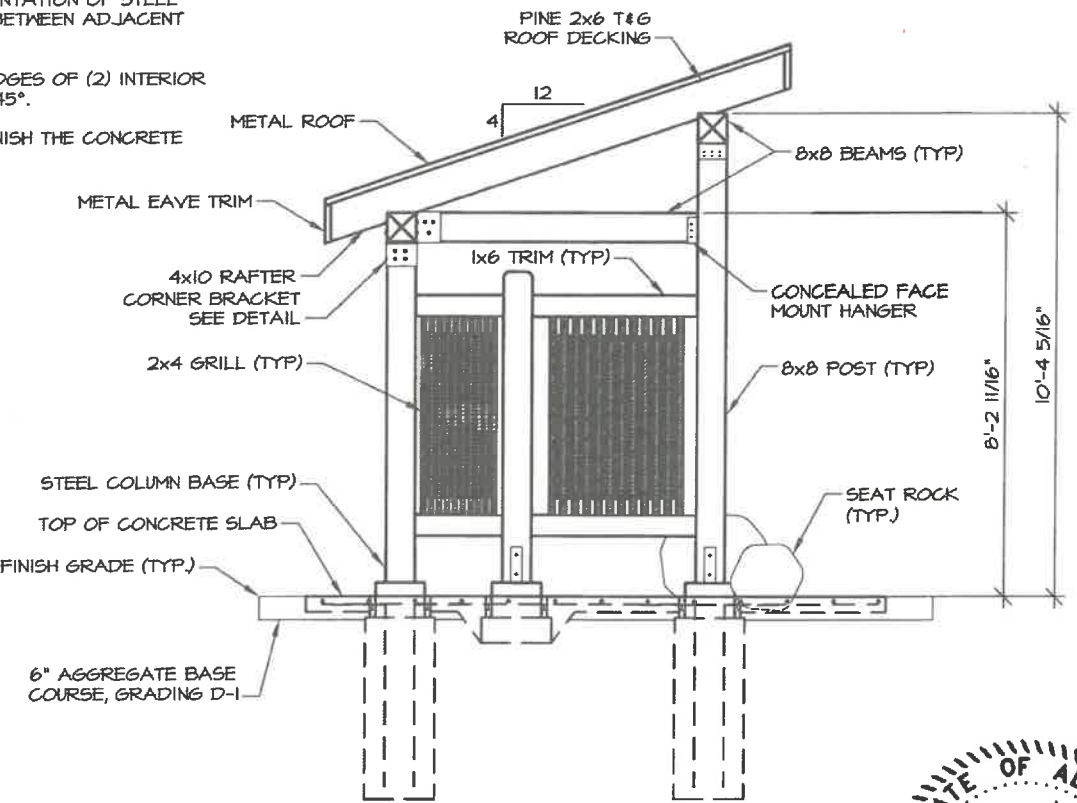

ORIENTATION KIOSK
 PLAN & PROFILE

NO.	REVISION	DATE	APPROVED
5	REPLACED STAMP	12/13	RBM
4	ADDED D-1 SHOULDER	12/10	MPS
3	CHANGED CONCRETE FOOTER, ADDED NOTE 3	12/10	MPS
2	UPDATED STATE PARK LOGO	12/10	MPS
1	CHANGED TITLE BLOCK	12/07	MPS

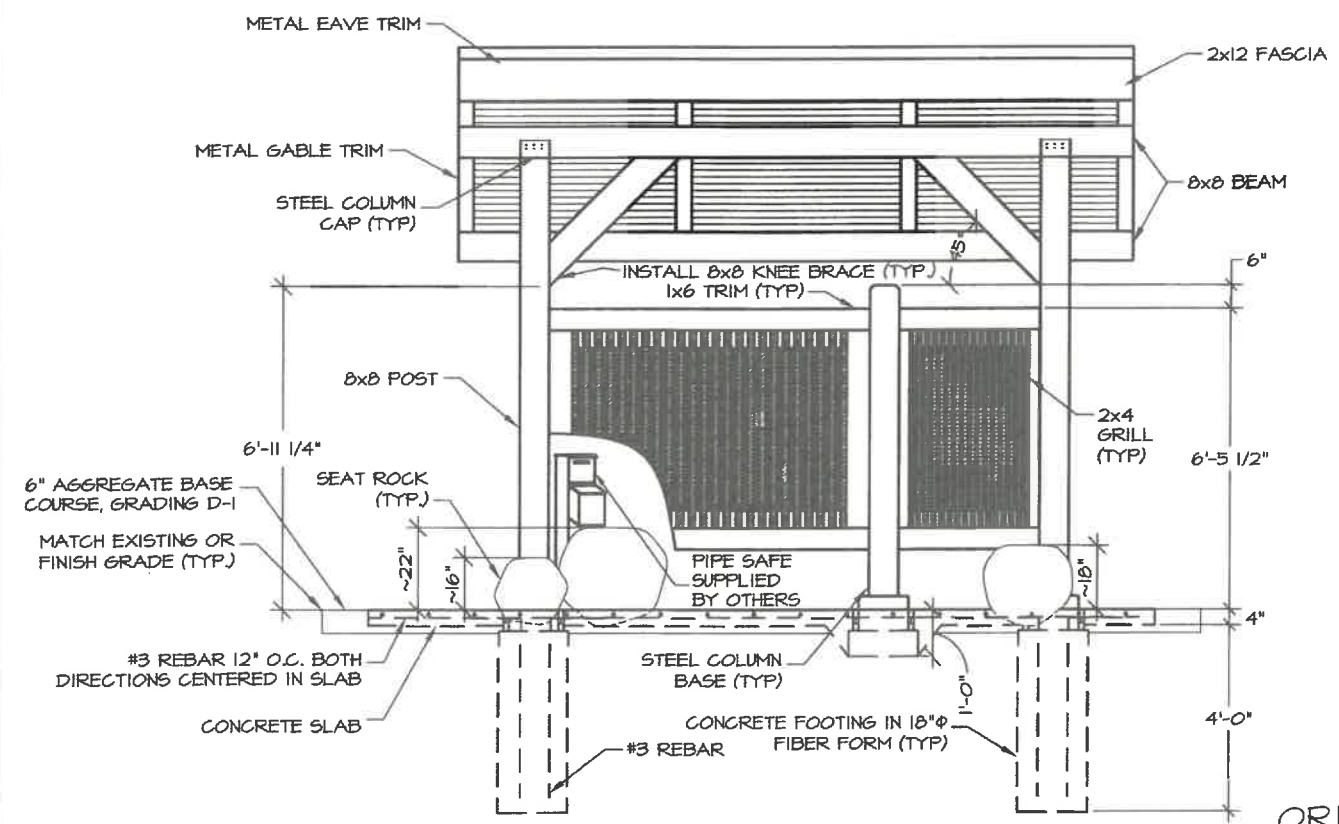
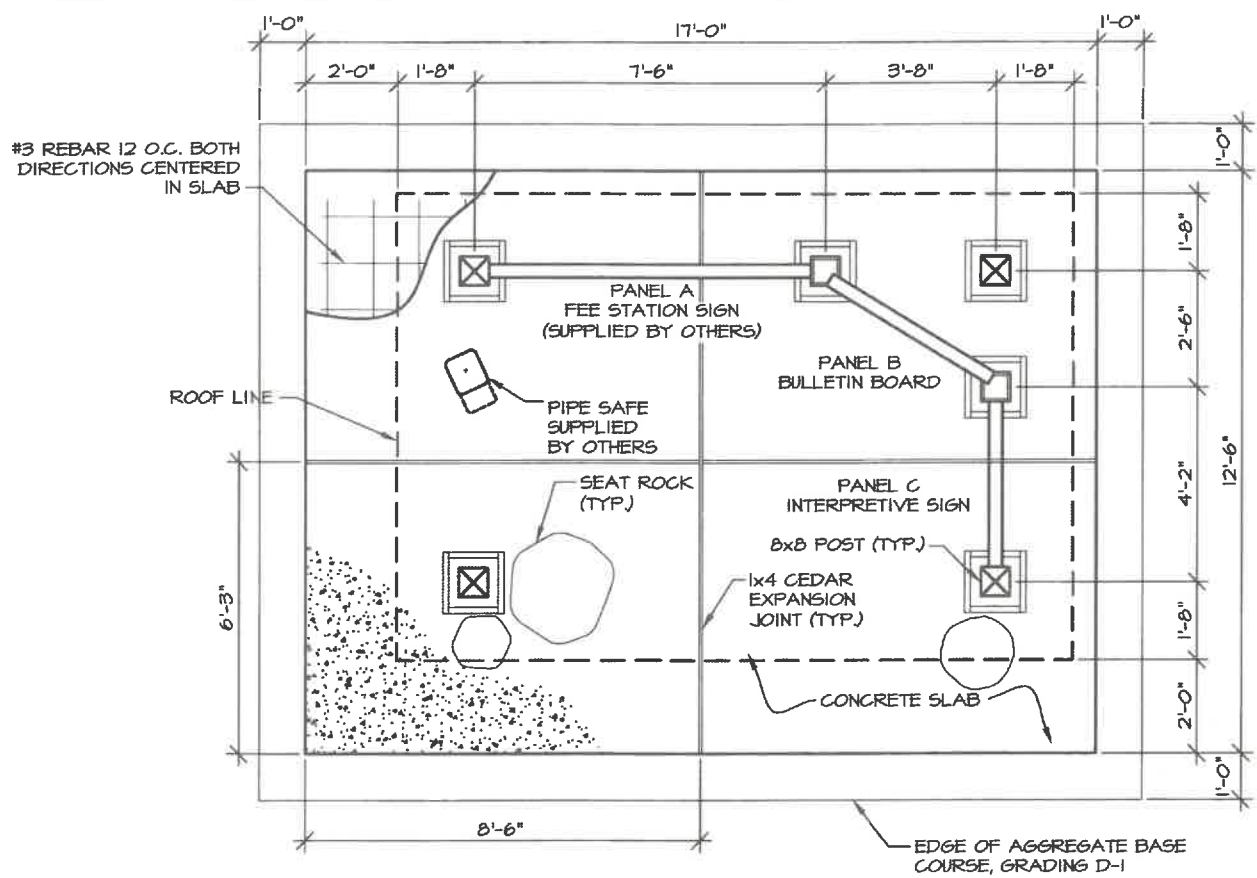



PREPARED: RBM/JAS
 DRAWN: AT/RBM/JAS
 REVIEWED: MPS
 DATE: JAN 2004

SHEET 2
 OF 3 SHEETS

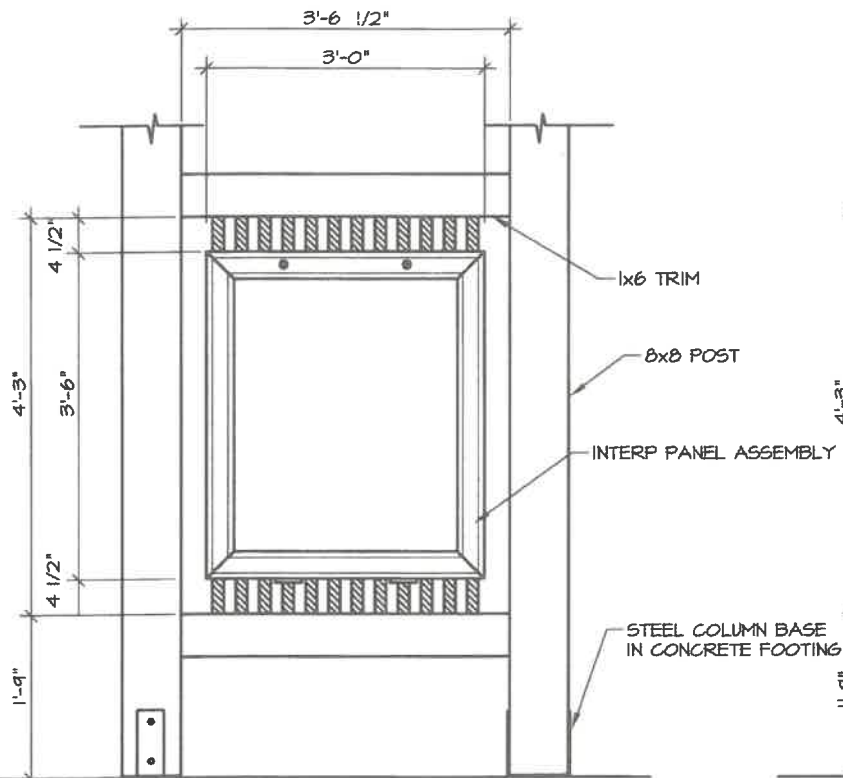

2x4 GRILL W/ INTERP PANEL
 DETAILS

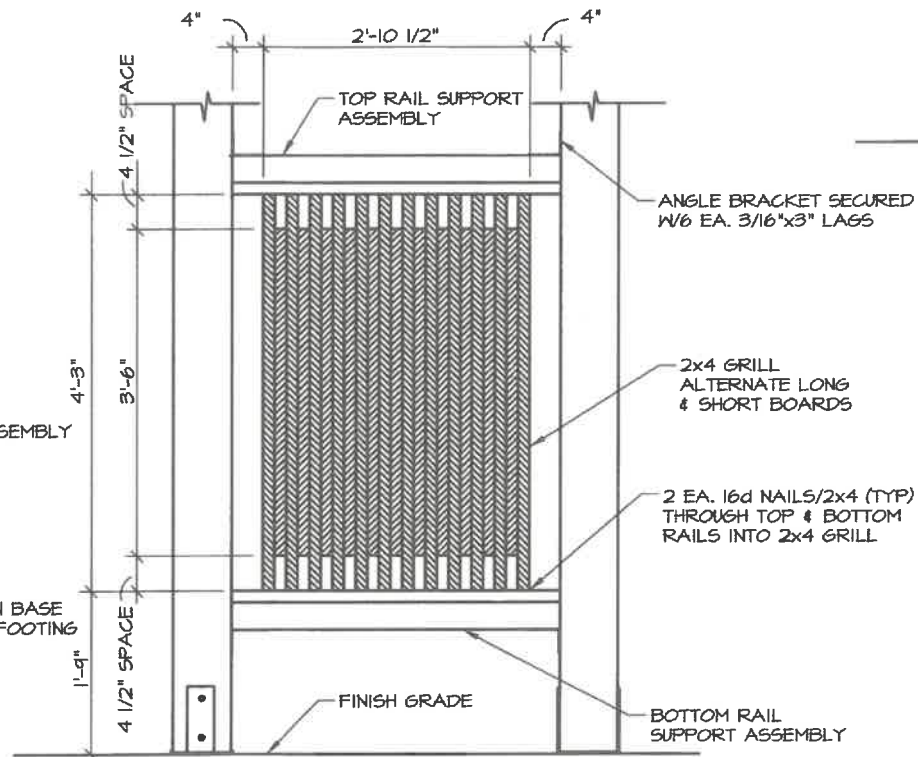

2x4 GRILL
 DETAILS - INTERP PANEL &
 1x6 TRIM NOT SHOWN

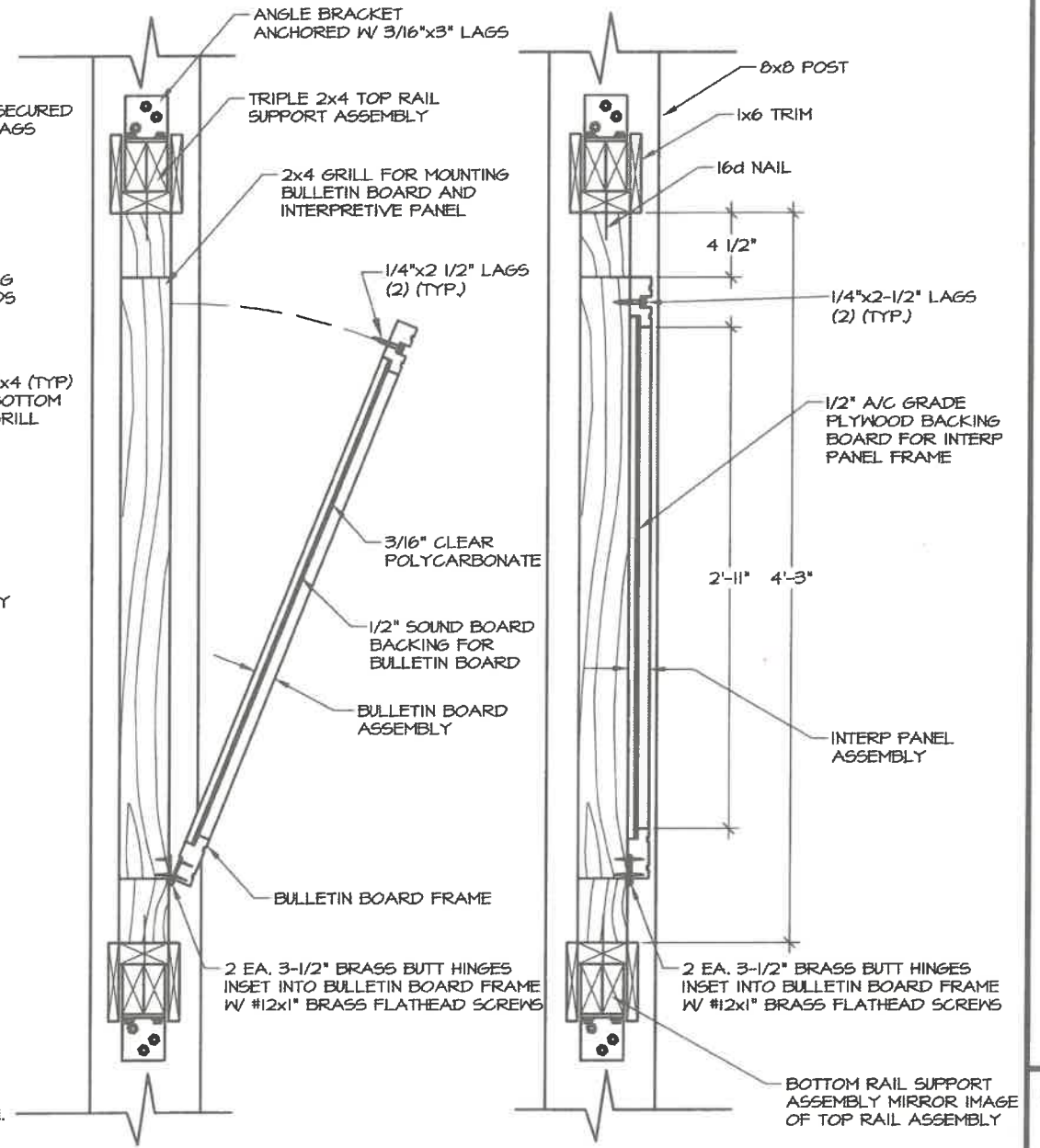

BULLETIN BOARD
 SECTION

SUPPORT GRILL
 SECTION

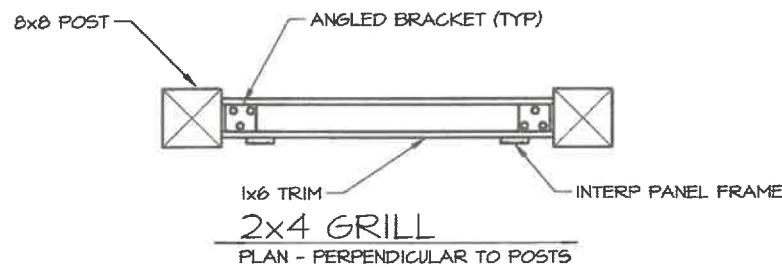

2x4 GRILL
 PLAN - PERPENDICULAR TO POSTS

- NOTES:
 1. NOTCH POSTS TO FIT ANGLE BRACKETS & TOP/BOTTOM SUPPORT RAILS.
 2. DO NOT NOTCH POSTS FULL LENGTH OF 2x4 GRILL.

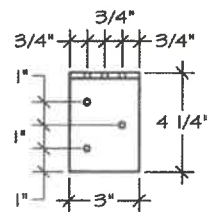

- NOTES:
 1. DRILL HOLES 1/4"φ.
 2. 1/4" MILD STEEL, (4) REQ'D PER SIGN.
 3. L4x3x1/4 MAY BE USED.

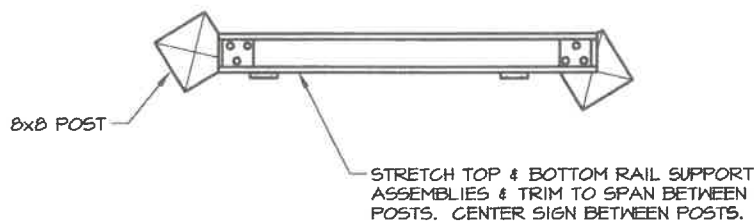

2x4 GRILL
 PLAN - ANGLED TO POSTS

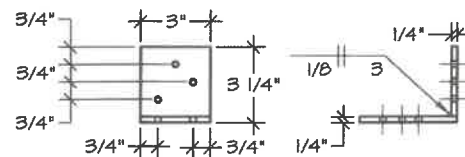

ANGLE BRACKET
 DETAILS

- NOTES:
 1. INTERPRETIVE PANEL ASSEMBLY CONSISTS OF INTERPRETIVE GRAPHIC BACKING BOARD AND INTERP PANEL FRAME.
 2. INTERPRETIVE GRAPHIC PANEL SUPPLIED BY OTHERS MEASURES 3'-0 1/2"x2'-6 1/2"x1/8". THE CONTRACTOR SHALL MAKE ACCOMMODATIONS FOR THIS GRAPHIC IN MEASUREMENTS AND CONSTRUCTION.

NO.	REVISION	DATE	APPROVED
4	REPLACED STAMP	12/13	RBM
3	CHANGED INTERP FRAME FASTENER SYSTEM	12/10	MPS
2	UPDATED STATE PARK LOGO	12/10	MPS
1	CHANGED TITLE BLOCK	12/07	MPS

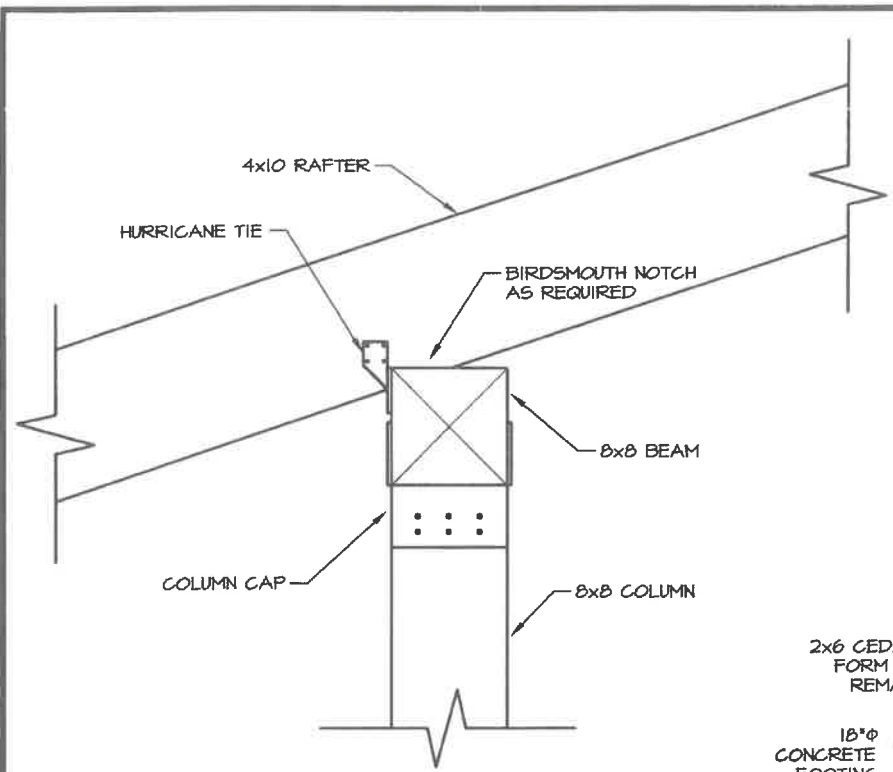

BEAM/RAFTER CONNECTION
 DETAILS - 2x6 T&G DECKING & METAL ROOF NOT SHOWN

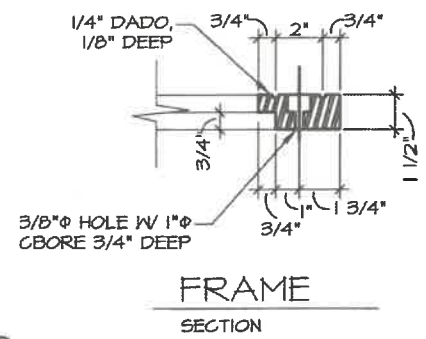

FRAME SECTION

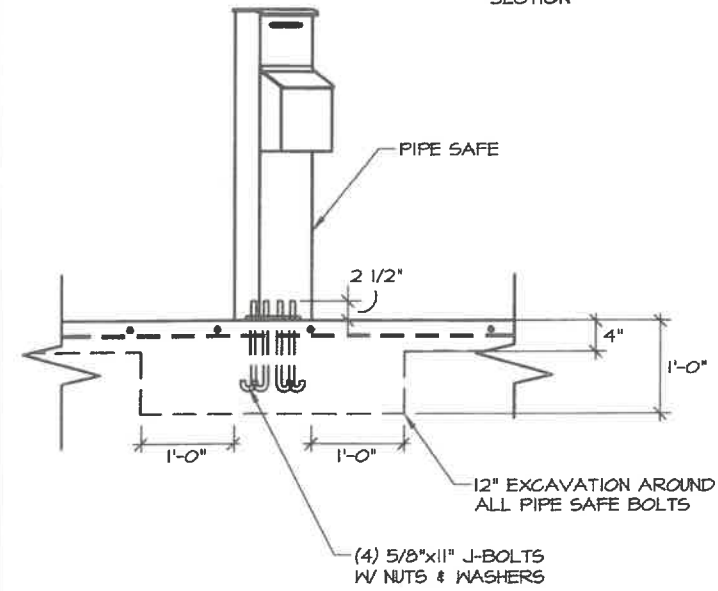

PIPE SAFE DETAILS

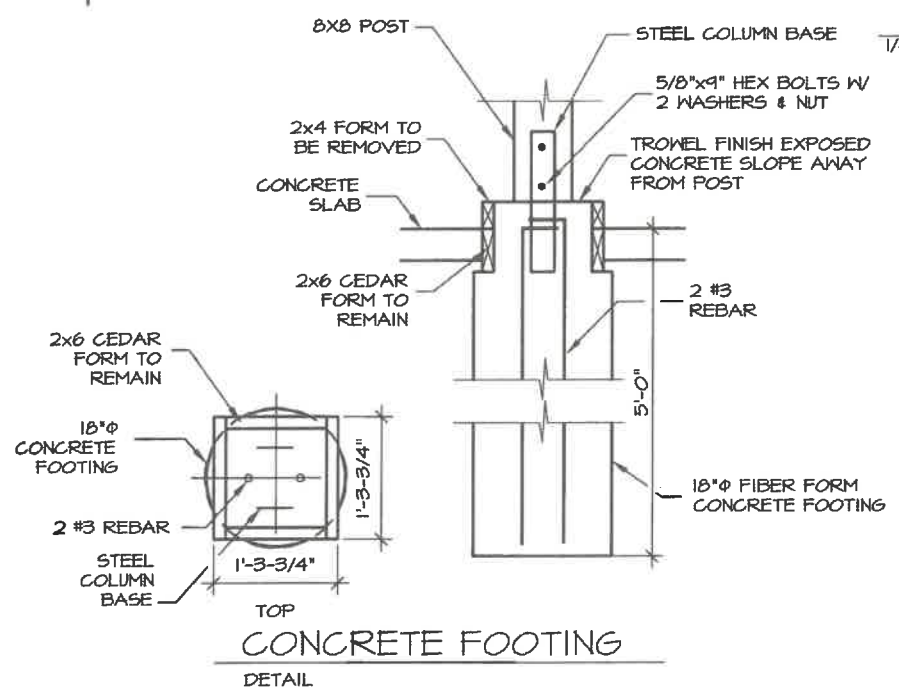

CONCRETE FOOTING
 TOP DETAIL

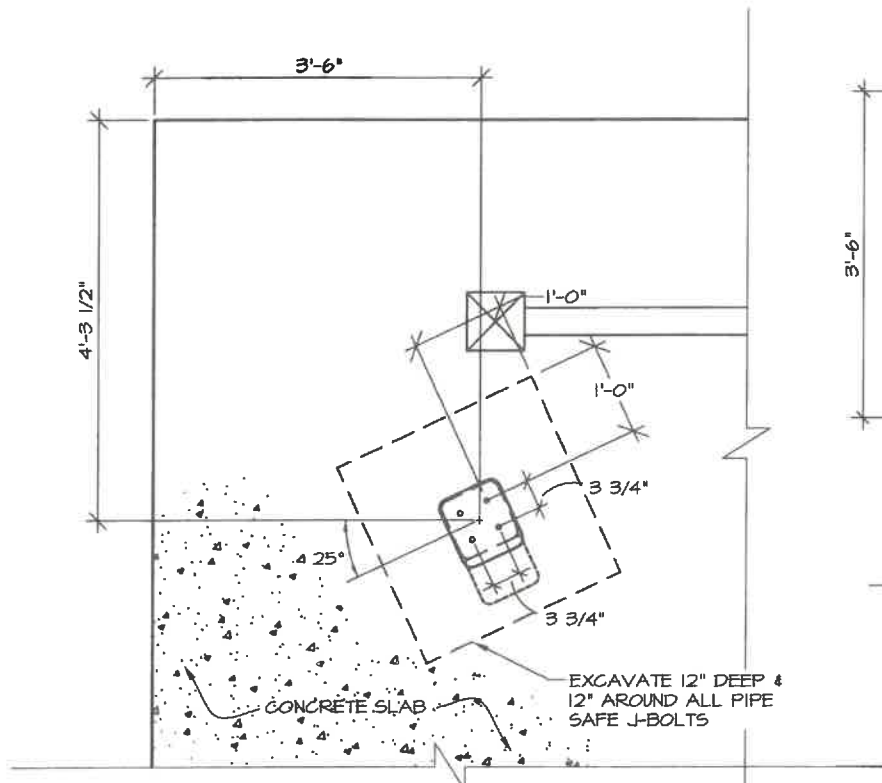

PIPE SAFE BOLT PATTERN
 DETAILS

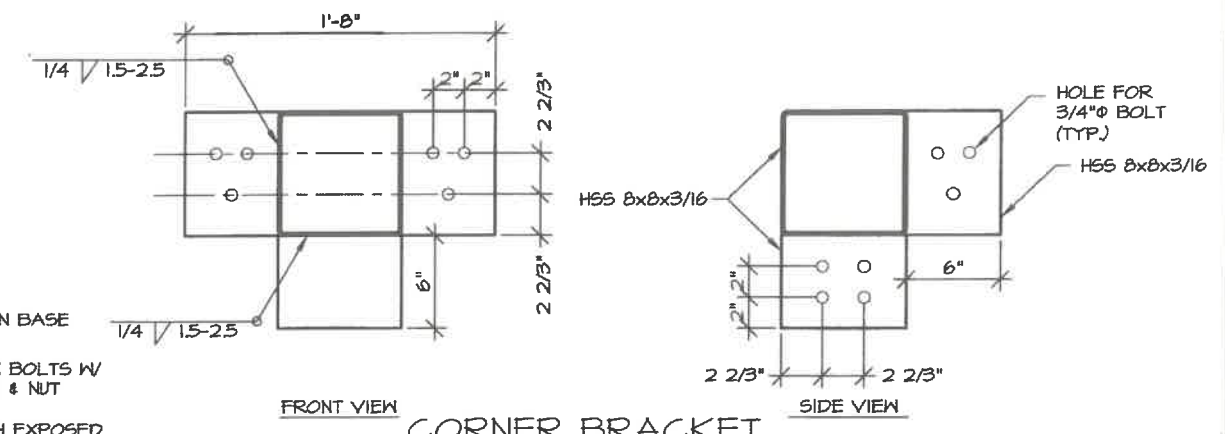

CORNER BRACKET
 FRONT VIEW
 SIDE VIEW

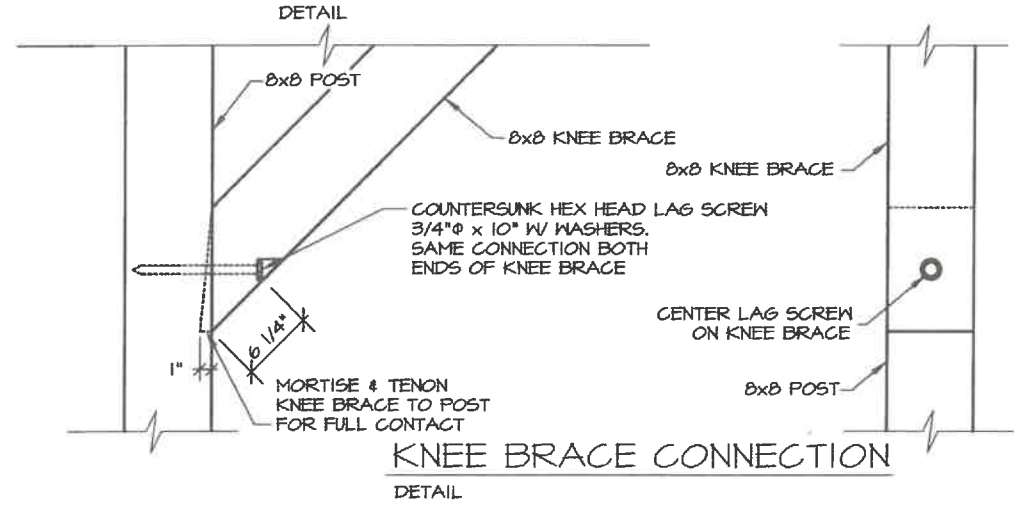

KNEE BRACE CONNECTION
 DETAIL

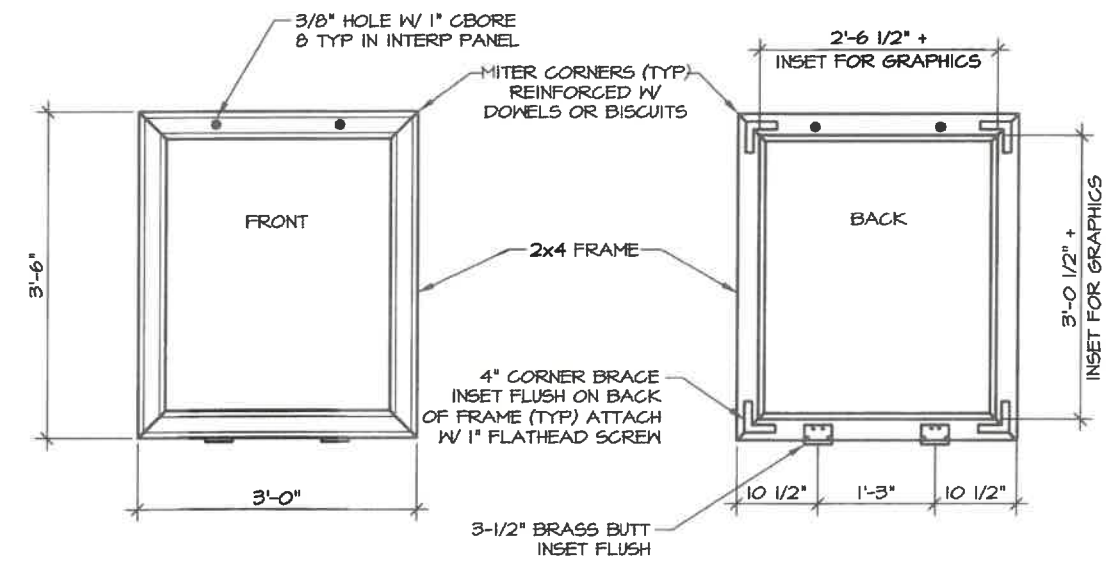

INTERP PANEL/BULLETIN BOARD FRAME
 DETAILS

NO.	REVISION	DATE	APPROVED
7	REPLACED STAMP	12/13	RBM
6	INCREASED THE SIZE OF THE J-BOLTS	12/10	MPS
5	ADDED COCRETE FOOTER DETAIL	12/10	MPS
4	ADDED KNEE BRACE CONNECTION DETAIL	12/10	MPS
3	UPDATED STATE PARK LOGO	12/10	MPS
2	CHANGED TITLE BLOCK	12/07	MPS
1	RELOCATED PIPE SAFE	8/07	MPS



PREPARED: RBM/JAS
 DRAWN: AT/RBM/JAS
 REVIEWED: MPS
 DATE: JAN 2004

SHEET 9
 S-10D
 OF 9 SHEETS

GENERAL NOTES

1. See the standard specifications for the aluminum alloys that you may use for sign sheeting and wind framing members.
2. Fabricate all signs from 0.125" thick aluminum sheeting.
3. Sign fabricators may use alternates to the zee shaped framing member with approval of the engineer, if the frame manufacturer certifies their design equals or exceeds the strength of the zee shaped design.
4. Install one piece wind framing members on all signs up to 23.5' wide. Use one splice in each wind frame on all signs wider than 23.5'. Locate splices at least 18" from all posts and panel edges. Stagger splices in adjacent framing members at least 8.0' apart.
5. Attach wind framing members with rivets or with an engineer approved, double sided, high strength, adhesive tape. Clean and handle sheeting and framing members and apply tape in accordance with the tape manufacturer's written instructions. Install two rivets in both ends of each framing member.
6. Use 3/16" diameter rivets conforming to aluminum alloy 6061-T6 for cold driven rivets, or aluminum alloy 6061-T43 for hot driven rivets.
7. Sign fabricators may use sign panels extruded with integral framing with approval of the engineer, if the manufacturer certifies their design equals or exceeds the strength of the 0.125" thick panel with framing attached to it.
8. Frame all signs taller than 8.0' with five wind framing members located (H-0.15)/4 spaces. If needed, make a horizontal splice at the middle wind frame.
9. Do not use round pipes for sign supports.

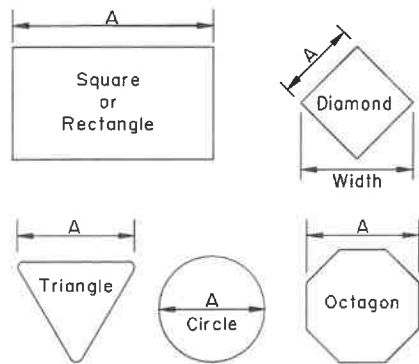
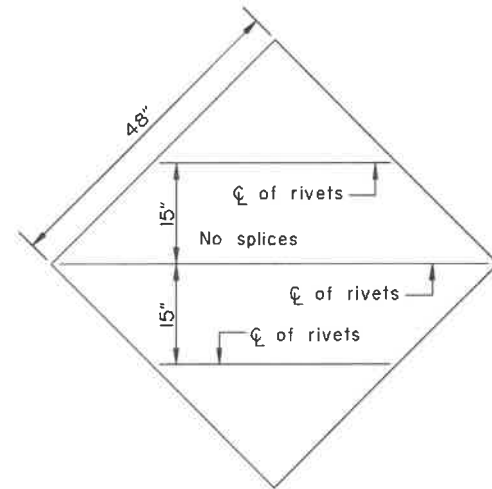

Maximum size unframed signs using 0.125" thick aluminum sheeting.	
Sign Shape	A
Squares, Shields, and Route Markers	48"
Rectangles	48"
Diamonds	48"
Triangles	48"
Rounds and Octagons	48"

Install wind framing on all signs that exceed the dimensions listed.

LIGHT SIGNS

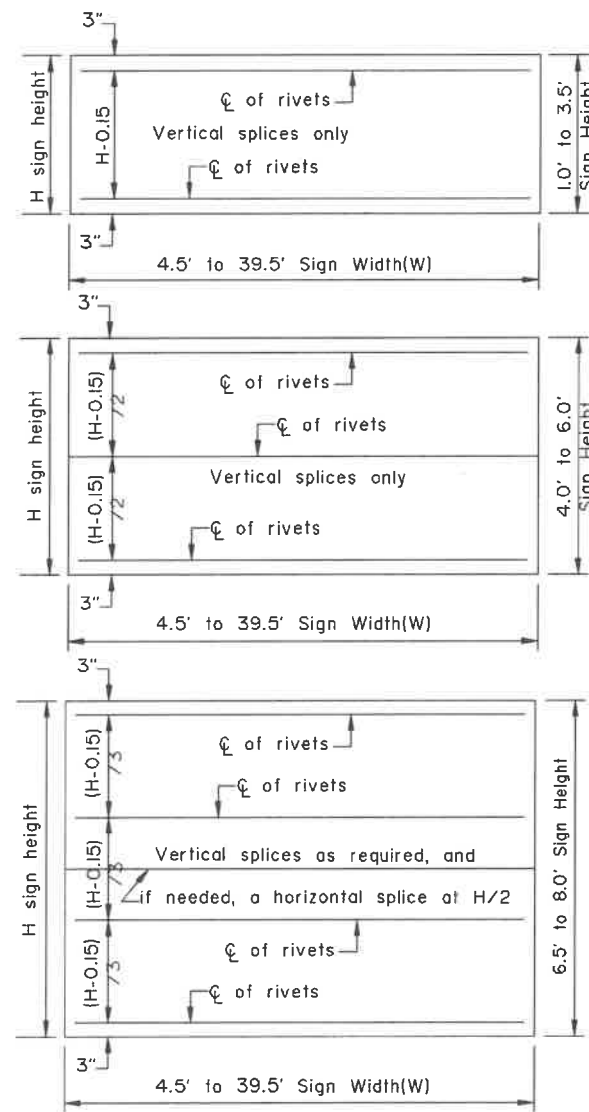

WIND FRAMING LOCATIONS

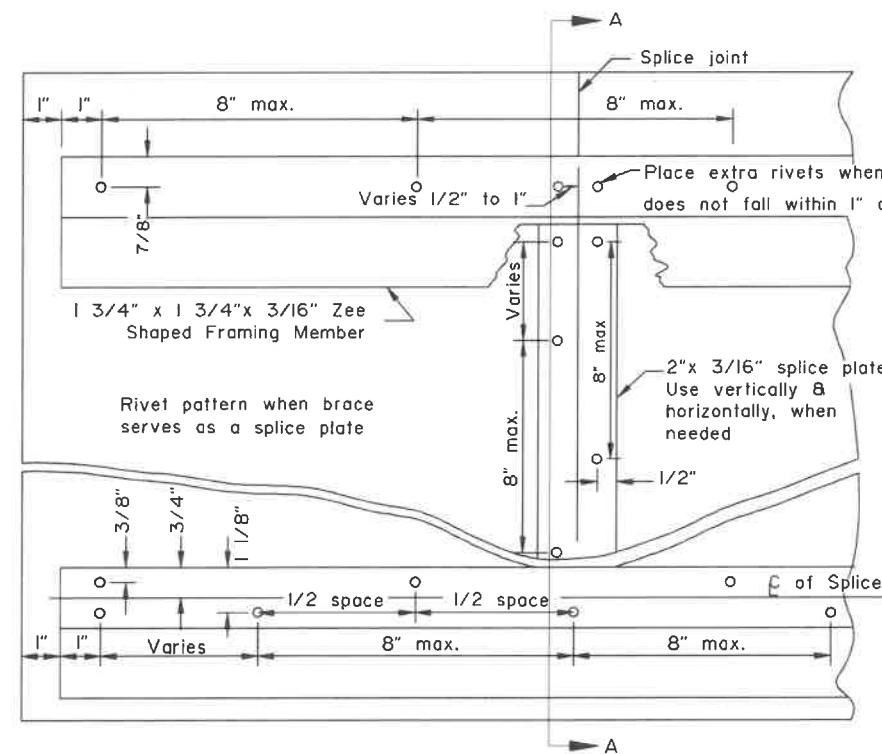

RIVET DETAIL FOR ZEE SHAPED WIND FRAMING & SPLICE PLATE

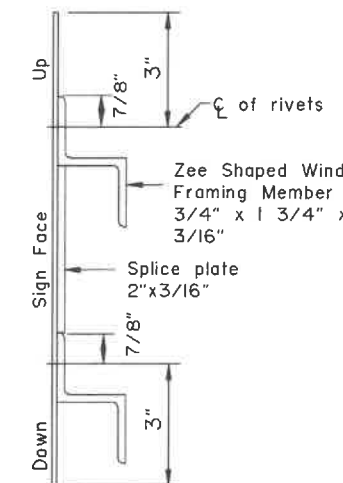

SECTION A-A

Note: Drawing not to scale

State of Alaska DOT&PF
ALASKA STANDARD PLAN

SIGN FRAMING

Adopted as an Alaska Standard Plan by: *Carolyn Morehouse*

Carolyn Morehouse, P.E.
Chief Engineer

Adoption Date: 7/17/2020

Last Code and Stds. Review
By: WTH Date: 7/8/2020

Next Code and Standards Review date: 7/8/2030

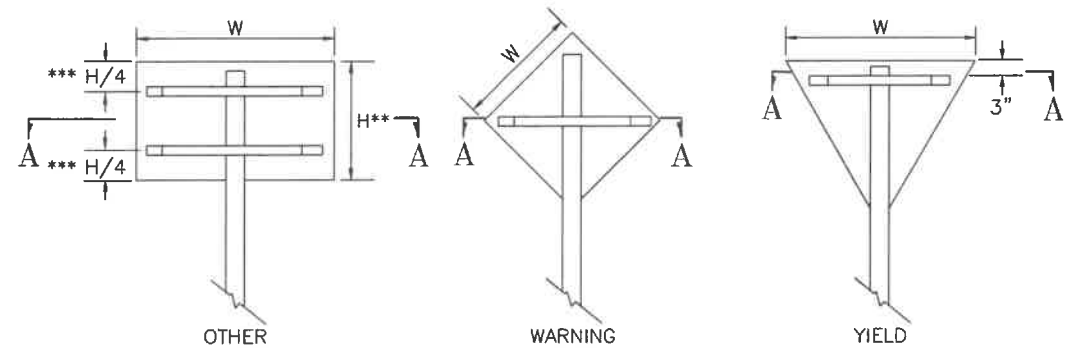

*** Use one brace when $H \leq 18"$
 Use two braces when $18" < H < 48"$
 Use three braces when $H \geq 48"$
 ** Position of brace may be varied to match
 Pre-drilled mounting holes in panel

SIGN BRACING PLACEMENT

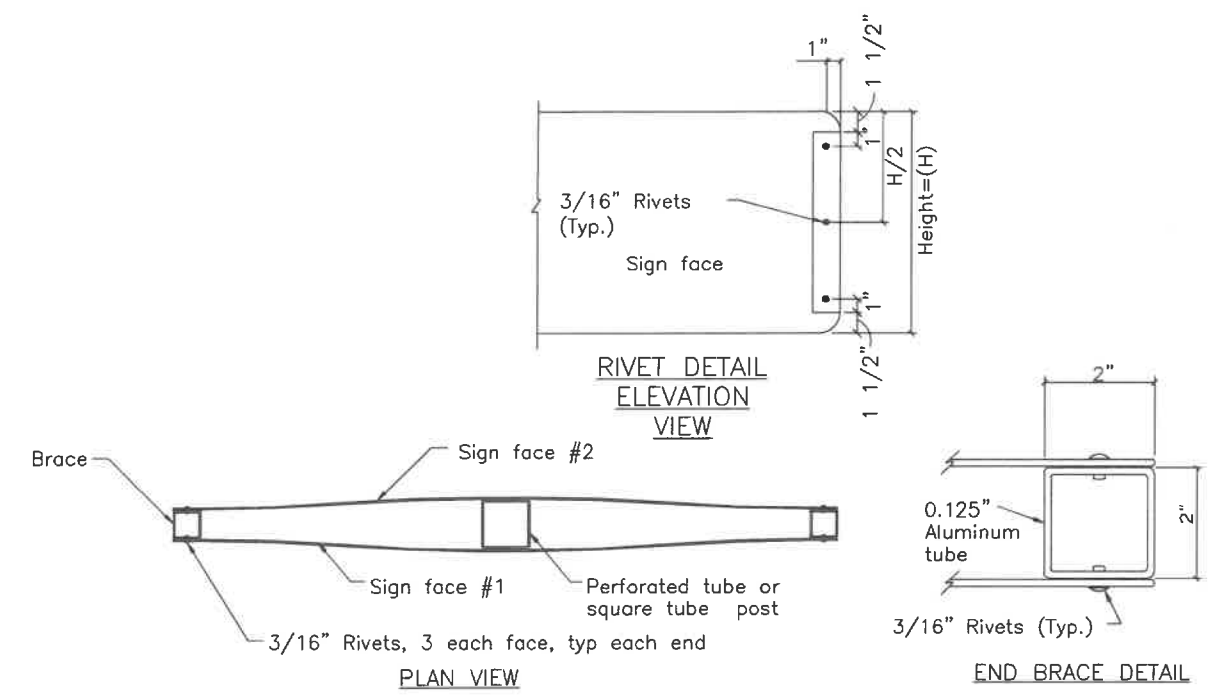

SMALL STREET NAME SIGN (D3-1, D3-1A, D3-1D) BRACING DETAILS

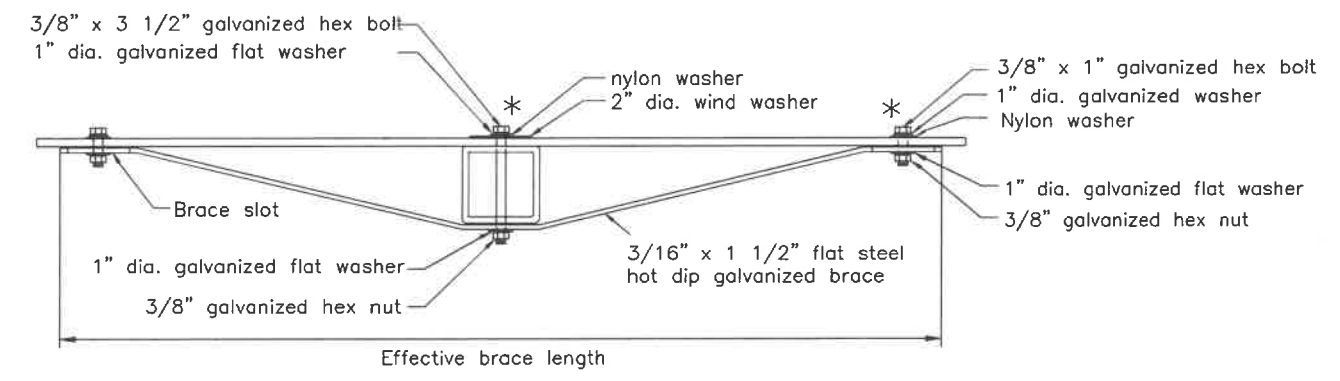
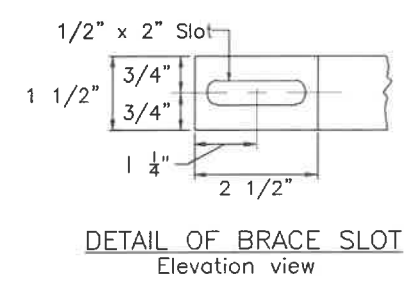

TUBE POST SIGN BRACING SECTION A-A
Plan view

* Adjust location of bracing so that bolts and washers will miss the sign legend

Sign Width(W)	Effective Brace Length		
	Warning	Yield	Other
30"	36"	24"	24"
36"	42"	30"	30"
42"	48"	-	36"
48"	Two posts	36"	42"

< 30" No bracing required and use square tube

Note: Drawing not to scale

State of Alaska DOT&PF
 ALASKA STANDARD PLAN
**BRACING FOR SIGNS
 MOUNTED ON SINGLE POST**

Adopted as an Alaska
 Standard Plan by: *Carolyn Morehouse*
 Carolyn Morehouse, P.E.
 Chief Engineer

Adoption Date: 7/17/2020

Last Code and Stds. Review
 By: WTH Date: 7/8/2020

Next Code and Standards Review date: 7/8/2030

S-01.02

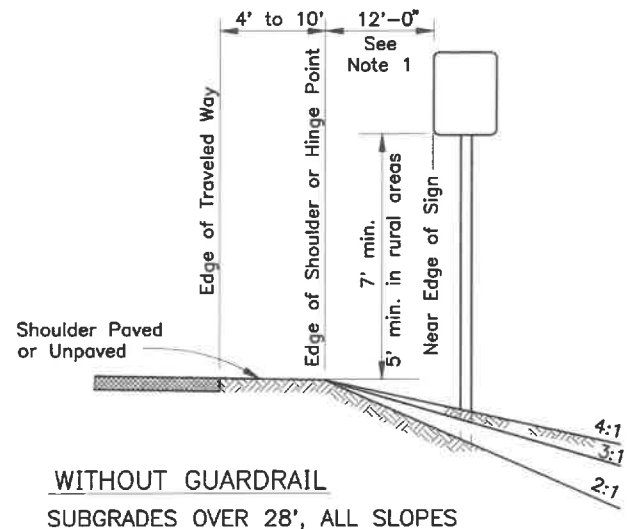

WITHOUT GUARDRAIL
SUBGRADES OVER 28', ALL SLOPES

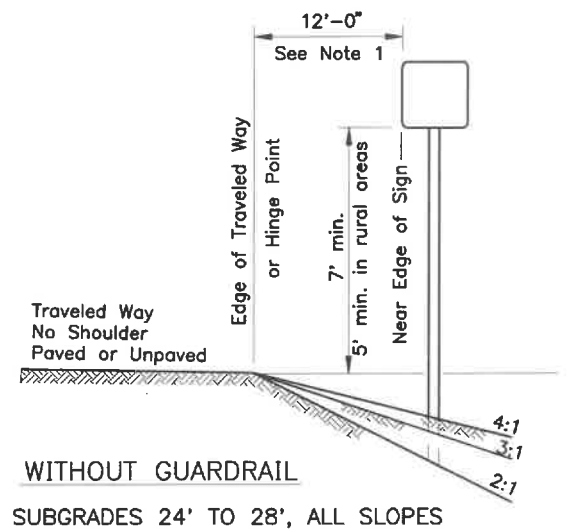

WITHOUT GUARDRAIL
SUBGRADES 24' TO 28', ALL SLOPES

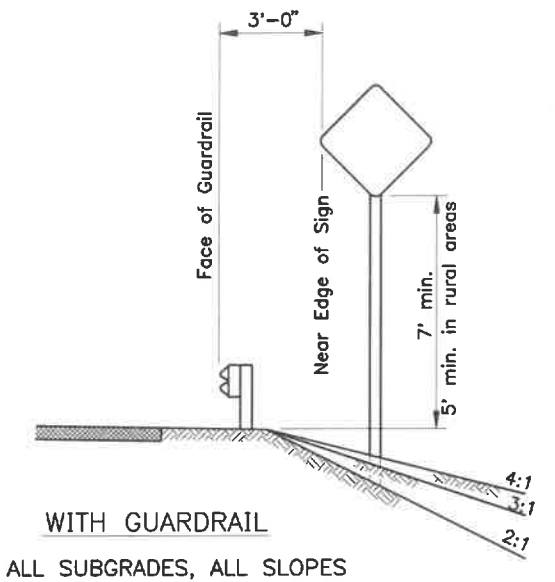

WITH GUARDRAIL
ALL SUBGRADES, ALL SLOPES

GENERAL NOTES

1. Unless shown otherwise on the plans, the standard sign offset is 12'. The minimum is 6' where shoulder width is 6' or greater.
2. Add 6" to mounting height on unpaved roads.
3. If signs extend over bike paths, the minimum vertical clearance is 8' 0".
4. When signs are placed 30' or more from the edge of traveled way, mount them with the bottom of the sign at least 5' above the road surface at the near edge of the road.
5. When multiple hinged sign supports are used, mount hinges at least 7' above the ground.
6. Minimum mounting height is 7'-0" where parking or pedestrian movements are likely to occur, or where signs extend over sidewalks.
7. For construction signs in rural areas, mounting height shall be 7' minimum.

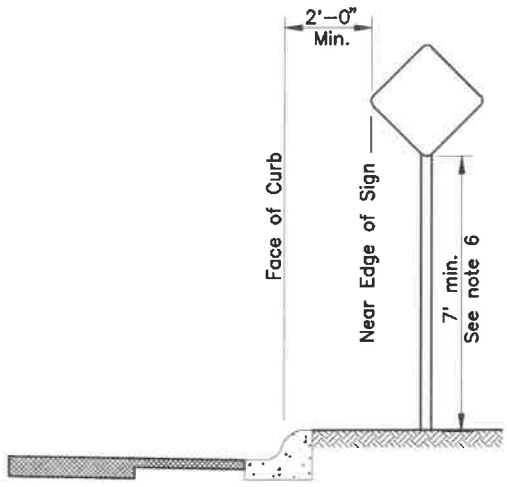

CURB WITHOUT SIDEWALK

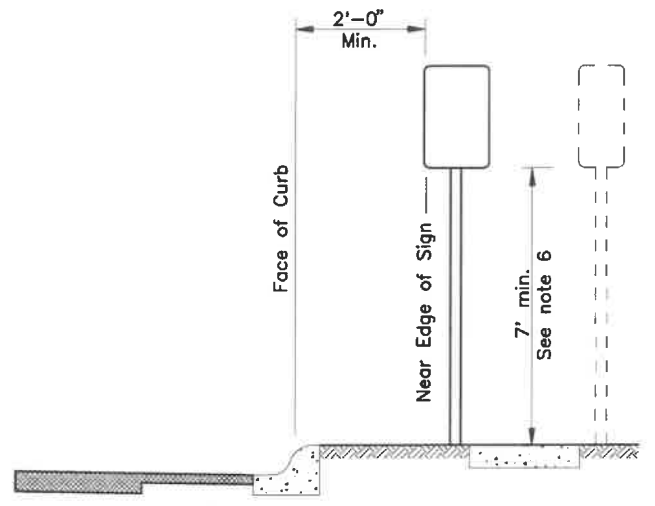

CURB WITH PARKWAY AND SIDEWALK
(If R/W width permits, signs should be placed behind sidewalk.)

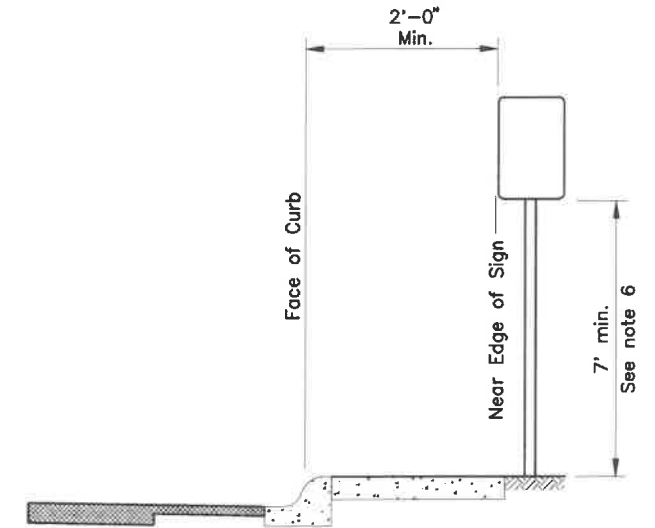

CURB WITH SIDEWALK WITHOUT PARKWAY

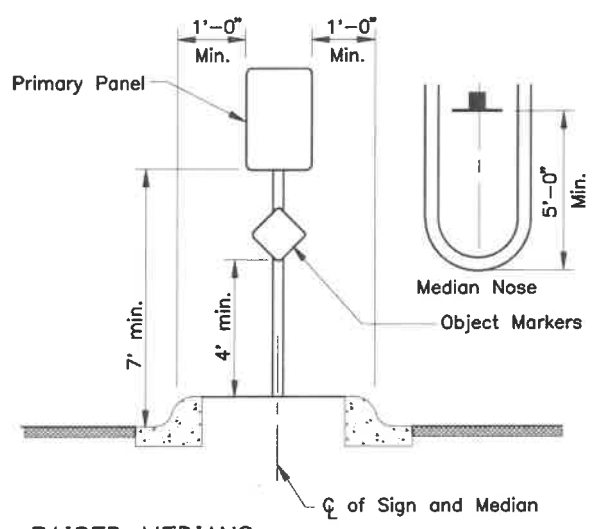

RAISED MEDIANS
Minimum 4' Width for Signing

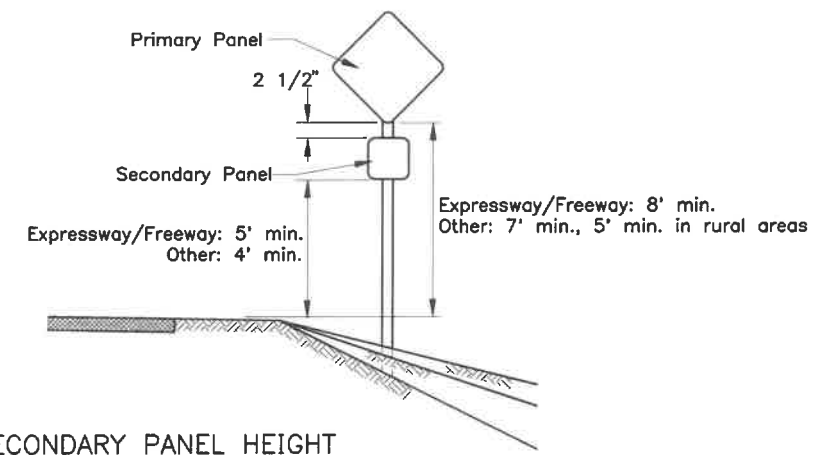

SECONDARY PANEL HEIGHT
ALL TWO PANEL MOUNTING

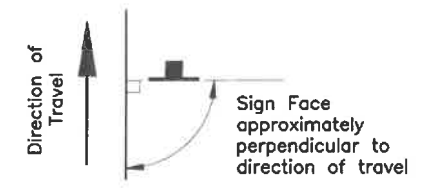

SIGN POSITIONING

State of Alaska DOT&PF
ALASKA STANDARD PLAN

POST MOUNTED SIGN
OFFSET AND HEIGHT

Adopted as an Alaska Standard Plan by *Carolyn Morehouse*
Carolyn Morehouse, P.E.
Chief Engineer

Adoption Date: 7/17/2020

Last Code and Stds. Review
By: KLK Date: 7/8/2020

Next Code and Standards Review Date: 7/8/2030

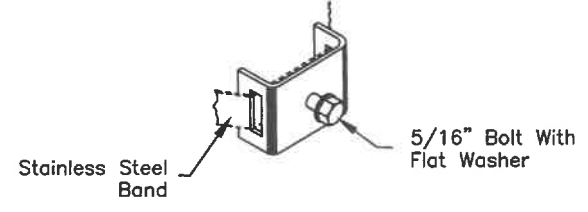
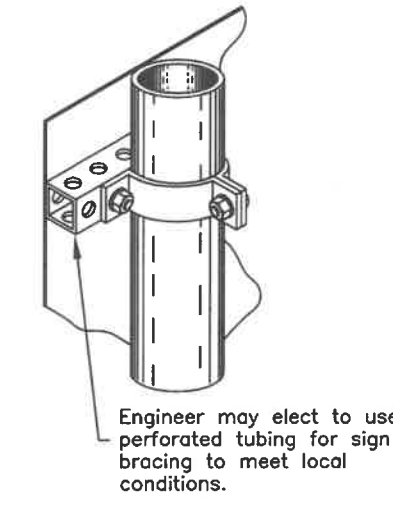
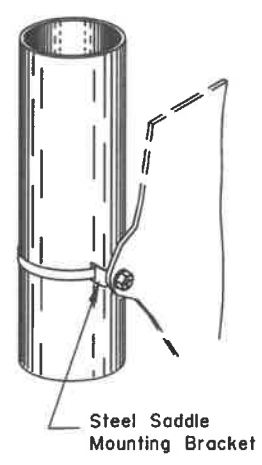
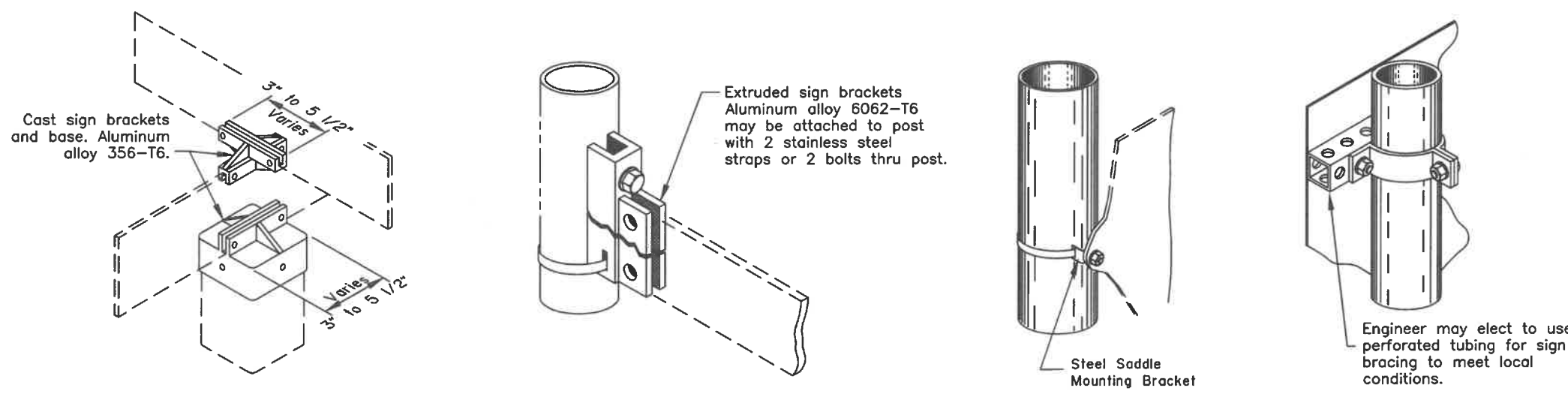

MOUNTING BRACKET DETAIL

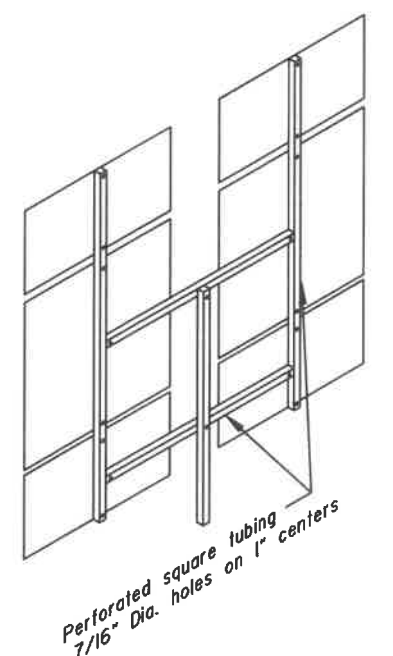
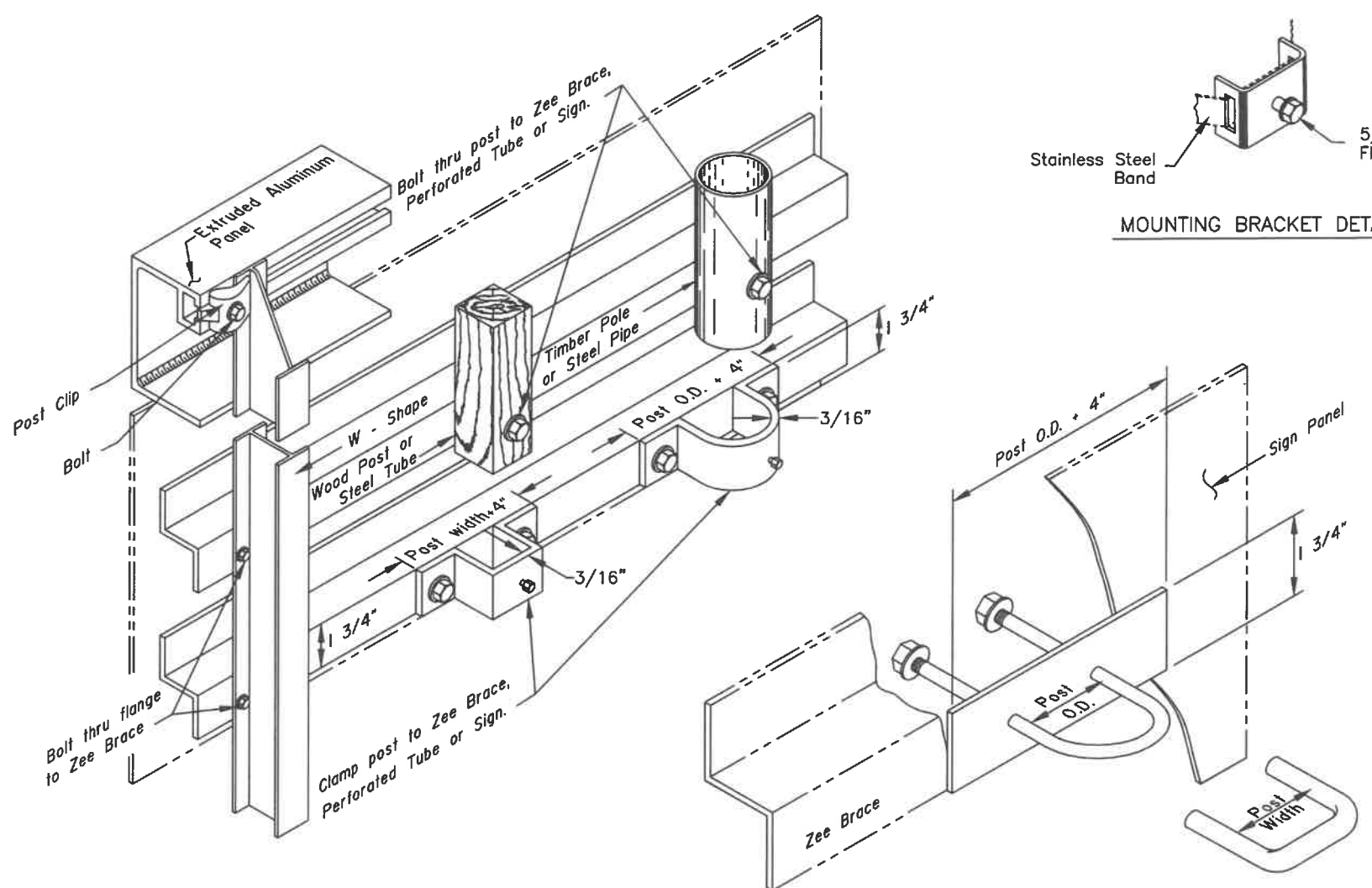

CONSTRUCTION NOTES

1. Details shown indicate general design only. Dimensions and design may vary among manufacturers.
2. Install weather tight caps on all pipe and tube post (except perforated tubing).
3. Protect driven sign posts with drive caps during installation.
4. Bolt braces to posts at each point where they cross posts.
5. Install signs with top of post, mounting brackets, etc. with a minimum of 3" below top of sign.
6. Paint all sign mounting fasteners on sign face a color closely matching the sign face.
7. Attach all signs, zees and braces mounted to the posts with 5/16" bolts, nuts and washers.
8. Furnish all aluminum nuts, bolts and washers with anodized finish.

FASTENER SPECIFICATION TABLE				
(ALL REFERENCES ARE TO ASTM)				
FASTENERS	ALUMINUM	STEEL	STAINLESS STEEL	
BOLTS	MACHINE	F468 2024-T4	A307	F593
	CARRIAGE "U"	F468 2024-T4	A307	A276 TYPE 304
NUTS	REGULAR	F467 6061-T6	A563	F594
	LOCKING	F467 2017-T4		
WASHERS	F468 2024-T4	F844	A480	
POST CLIP	A356-T6	N/A	N/A	

State of Alaska DOT&PF
ALASKA STANDARD PLAN

SIGN TO SIGN POST CONNECTION

Adopted as an Alaska Standard Plan by: *Carolyn Morehouse*
Carolyn Morehouse, P.E.
Chief Engineer

Adoption Date: 07/30/2021

Last Code and Stds. Review
By: LRG Date: 07/30/2021

Next Code and Standards Review date: 07/30/2031

NOTE:
Install hinges when more than one post is used to support a sign. Do not install hinges on single post installations.

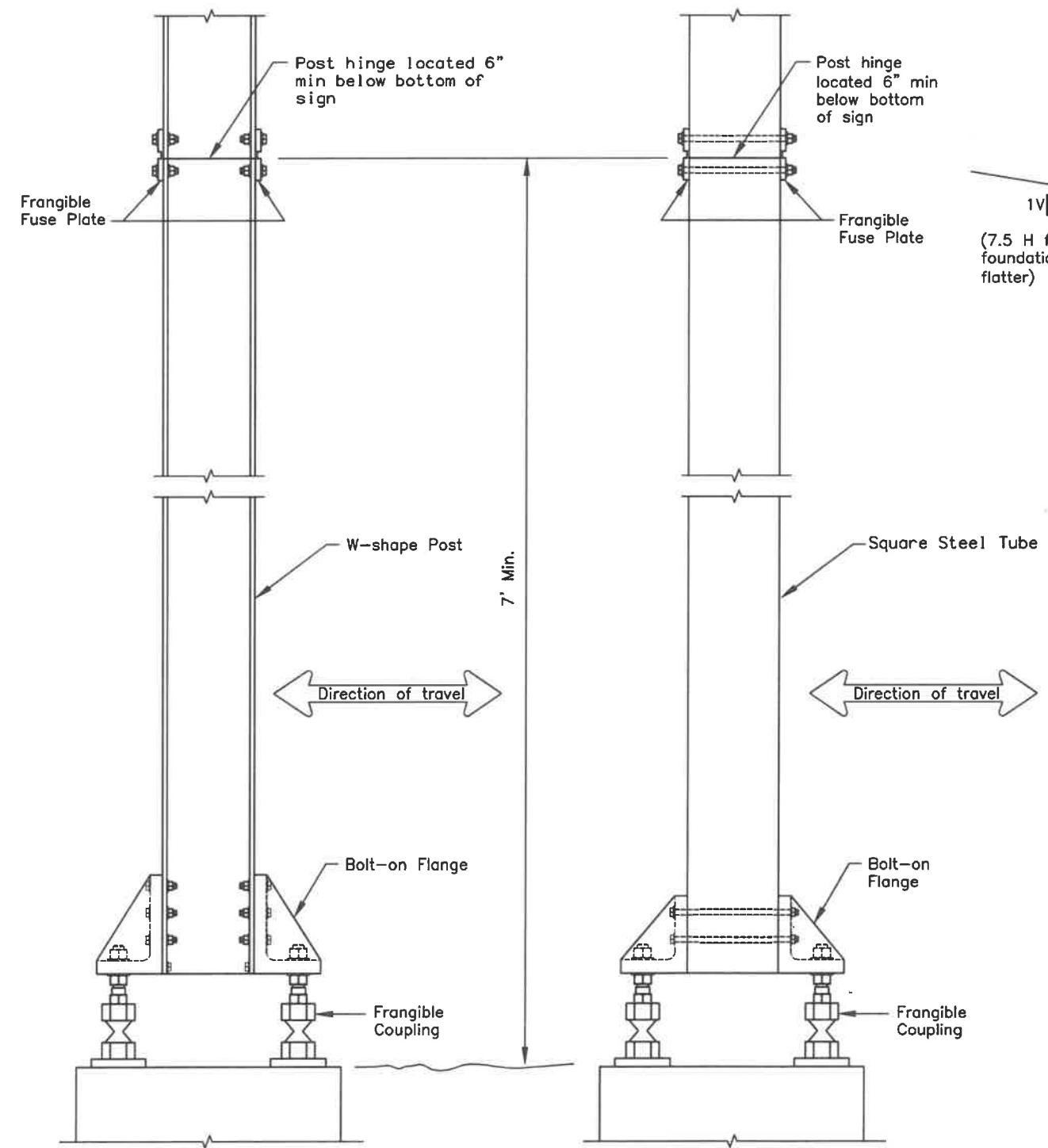

FRANGIBLE COUPLING SYSTEM FOR W-SHAPE POST

FRANGIBLE COUPLING SYSTEM FOR SQUARE STEEL TUBES

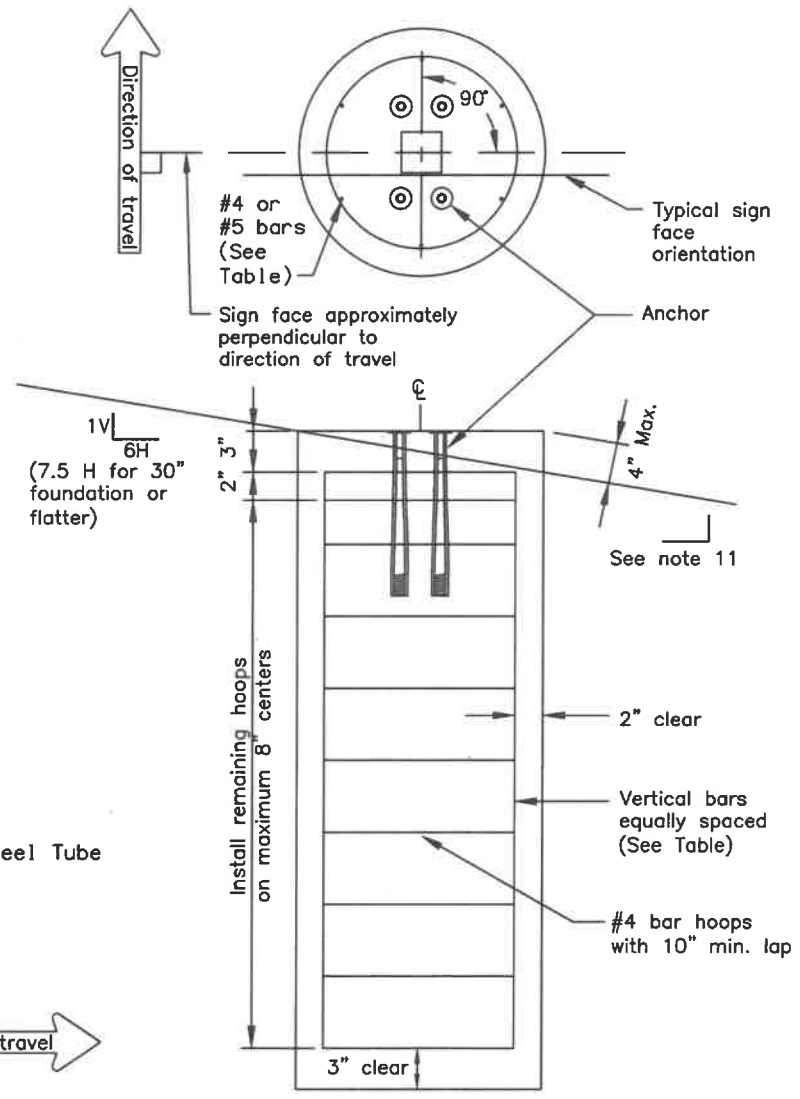

SIGN POST FOUNDATION
See Table for depth and diameter

POST SIZE & TYPE	FOUNDATION *			REINFORCEMENT					
	DIA.	MIN. DEPTH	CY ³ CONC.	VERTICAL BARS	HOOPS				
				QTY	SIZE	LGTH.	QTY	SIZE	DIA.
2 1/2" TUBE	1'-6"	6'-0"	0.39	7	#5	5'-6"	10	#4	1'-2"
3" TUBE	1'-6"	6'-0"	0.39	7	#5	5'-6"	10	#4	1'-2"
3 1/2" TUBE	1'-6"	6'-0"	0.39	7	#5	5'-6"	10	#4	1'-2"
4" TUBE	2'-6"	6'-0"	1.09	8	#8	5'-6"	10	#4	2'-2"
4 1/2" TUBE	2'-6"	6'-0"	1.09	8	#8	5'-6"	10	#4	2'-2"
5" TUBE	2'-6"	6'-0"	1.09	8	#8	5'-6"	10	#4	2'-2"
W6 x 9	2'-6"	6'-0"	1.09	8	#8	5'-6"	10	#4	2'-2"
W6 x 12	2'-6"	6'-0"	1.09	8	#8	5'-6"	10	#4	2'-2"
W6 x 15	3'-0"	6'-6"	1.70	8	#11	6'-0"	12	#4	2'-8"
W6 x 30	3'-0"	7'-6"	1.96	8	#11	7'-0"	13	#4	2'-8"

FOUNDATION TABLE

* Foundations sized for use where there are no loose, high moisture, or fine grained soils.

GENERAL NOTES

1. Furnish sign posts with NCHRP 350 compliant frangible couplings designed to break away safely when struck from any direction. There is no MASH compliant device at this time. See SPDR report for more info.
2. Furnish frangible coupling systems with bolt-on flanges.
3. Details on this sheet illustrate only the general components of a frangible coupling system, and are not intended to specify a particular product.
4. Install frangible fuse plates as specified by the manufacturer and hinged joints when multiple posts are used to support a sign. Do not use round pipes.
5. Install the components of the breakaway system, including hinges, in accordance with the written instructions of the system manufacturer.
6. Use Class A, B or W concrete conforming to Sections 501 or 550 of the Standard Specifications. Furnish ASTM A615 grade 60 steel bars for concrete reinforcement conforming to AASHTO M31.
7. Spiral reinforcing steel may be substituted for hoops in concrete foundation. Spiral option shall consist of #3 plain spiral with 6" pitch with three flat turns at the top and one flat turn at the bottom.
8. Install the concrete anchors using a rigid template. Locate the anchors on centers and within tolerances specified by the manufacturer.
9. Install the anchors in fresh concrete as recommended by the manufacturer. Adjust the template's final position until it is level. Remove and replace all foundations that need more than 2 shims under any 1 coupling or more than a total of 3 shims under any pair of couplings to plumb the post.
10. Drill the holes for attaching brackets before the sign posts are hot dip galvanized. Test fit templates in the holes to ensure the brackets can be installed square to the posts.
11. Special grading detail and/or shielding may be required to maintain 4" maximum clear distance.

State of Alaska DOT&PF
ALASKA STANDARD PLAN
SIGN POST BASE AND FOUNDATION

Adopted as an Alaska Standard Plan by: *Carolyn Morehouse*
Carolyn Morehouse, P.E.
Chief Engineer

Adoption Date: 7/17/2020

Last Code and Stds. Review
By: KLK, MJM Date: 7/8/2020

Next Code and Standards Review Date: 7/8/2030

S-31.02